

INSTRUCTION MANUAL

McINTOSH MODEL C-4 and C-4P

AUDIO COMPENSATORS

McINTOSH LABORATORY, INC.

320 Water St. Binghamton, N. Y.

U.S.A.

INSTRUCTION MANUAL

McINTOSH MODEL C-4 and C-4P

AUDIO COMPENSATORS

The McIntosh Audio Compensator is a complete control unit for professional or home entertainment systems. The Model C-4 derives its power from any McIntosh power amplifier; the Model C-4P is self-powered.

Five input channels are provided, three of which produce constant amplification over the audio spectrum of 20-20,000 cycles, one which is compensated for magnetic phonograph cartridges and one which is compensated for either magnetic or constant amplitude cartridges. Each input is equipped with a level control. A three output system is employed, two main outputs where all controls are effective and one tape output where only the channel selector and compensation selector are effective.

THE AUDIO COMPENSATOR IS A COMPLETE PRE-AMPLIFIER AND RECORD COMPENSATOR: THEREFORE, THE USE OF AN AUXILIARY EQUALIZER OR PRE-AMPLIFIER WITH THIS UNIT IS NOT RECOMMENDED.

INSTALLATION OF MODEL C-4 and C-4P AUDIO COMPENSATORS

The C-4 and C-4P Audio Compensator may be mounted in any type equipment cabinet, relay rack panel, door, wall, etc., or in its own cabinet for chair side operation. It is not necessary to disassemble the Audio Compensator for mounting. Using the mounting templates provided with this manual, cut a rectangular hole in the panel to be used for mounting, insert the Audio Compensator and secure with wood or machine screws.

When installing the C-4P, the power supply section should be mounted at least two feet from the Audio Compensator.

After these units have been secured, proceed as follows:

1. Connect speaker to output of power amplifier.
2. Insert power amplifier line cord into one of the Auxiliary A.C. receptacles provided at the rear chassis of the Audio Compensator.
3. C-4: Connect inter-unit cable to socket labeled "PRE-AMP INPUT" on McIntosh Power Amplifiers. CAUTION: THE INTER-UNIT CABLE MUST NOT BE REMOVED FROM THE C-4.

C-4P: Insert cable of D-8 power supply into socket labeled "INTER-UNIT CABLE" on C-4P. Connect audio cable provided between RETMA pin jack labeled "MAIN OUTPUT" on C-4P and 2.5V input of power amplifier. (Socket labeled "PRE-AMP INPUT" on McIntosh power amplifiers.)

4. The Audio Compensator delivers 2.5 volts of audio signal at full output. The gain control of the power amplifier should be adjusted as outlined in the amplifier instruction manual for this sensitivity. (McIntosh Amplifier Models A-116, MC-30, MC-60, set gain control fully counter clockwise; 50W-2 and 20W-2 fully clockwise.)
5. Turn the volume control on the Audio Compensator to "OFF".
6. Insert power cord of the Audio Compensator into a 117V., 50/60 cycle power outlet.
7. Turn the Selector Switch on the Audio Compensator to "5" and Bass control fully clockwise.
8. Turn the volume control on the Audio Compensator clockwise until the power switch is activated. Allow thirty seconds for warm-up, then advance the volume control to "10".
9. C-4: Adjust the hum reducing potentiometer on the power amplifier for minimum hum. C-4P: Adjust the hum reducing potentiometer on the power supply for minimum hum.
10. Turn the volume control on the Audio Compensator to "OFF".
11. Insert inputs into their proper jacks at the back of the Audio Compensator, and all A.C. power cords into the A.C. outlets provided.

INPUT CONNECTING PROCEDURE

The inherent hum and noise voltages applied to the input of the Audio Compensator are -110 DBM, or less than 3 microvolts. To avoid lowering the signal to hum ratio of the Audio Compensator, by adding hum voltages to the input, extreme care must be taken in its installation. We offer the following recommendations as a guide to installation:

1. Connect inputs of Audio Compensator as outlined on the table below.

CHANNEL	FOR USE WITH	INPUT		GAIN	REMARKS
		MIN.	MAX.		
TAPE AND TUNER	Radio or TV Tuners Tape Recorders Crystal or Ceramic cartridges Crystal Microphones	60MV	20V	32db	Inputs in excess of the recommended minimum should be reduced by the level adjustments located on the back panel. See text for complete operation.
MIC	Low Impedance Microphone	3MV	1V	52db	
PHONO 1 AND PHONO 2	Phonograph Cartridges (magnetic or constant amplitude)	3MV	1V	52db	

2. The Audio Compensator and magnetic phonograph cartridges should be mounted at least two feet from power transformers.
3. Inter-unit cables provide a complete ground system. Alternate ground wires should not be used since they will produce ground loops and increase the hum level.

4. The heaters of the 12AX7 tubes used in the C-4 are returned to ground through a hum reducing potentiometer in the power amplifier. Heaters of tubes used in the C-4P are returned to ground through a hum reducing potentiometer in the power supply. This control requires an initial adjustment for minimum hum, and should be readjusted each time one or more tubes are replaced.
5. Grounding the turntable motor frame to the Audio Compensator chassis near the input jacks may reduce the hum level on the phono-graph channels.

OUTPUT CONNECTIONS

Three outputs are provided: one tape and two main outputs.

The tape output may be used for recording tape from any source connected to the Audio Compensator. The Selector Switch, and Compensation Switch are effective at this output. Adjustment of the Bass and Treble tone controls and Volume control may be made without affecting the recorded signal. The tape output delivers a signal of one volt.

All controls are effective at the main outputs, which are available at the octal socket labeled "INTER-UNIT CABLE" between pins #1 and #2 (pin #1 is ground), and at the RETMA pin jack labeled "MAIN OUTPUT". The inter-unit cable connecting the C-4 to any McIntosh power amplifier uses the octal socket output. The pin jack output may be used for driving a second power amplifier if so desired.

The main and tape outputs are fed from cathode followers. The input impedance of devices connected to these outputs should be 50,000 ohms or greater, and the capacitive reactance of audio cables connecting these devices should not be less than 8,000 ohms at 20,000 cycles. This is the reactance of a capacity of 1000 mf. Audio cable having a capacity of 25 mmf per foot may be 40 feet long.

TAPE and TUNER Channels: These channels are each terminated by a potentiometer mounted on the back panel which should be used to reduce signal input if in excess of .1 volts. High impedance sources, such as crystal microphones and the detector output of tuners, may be connected directly to these channels since they have an input impedance of 660,000 ohms.

MIC Channel: This channel is terminated by a 100,000 ohm potentiometer mounted on the back panel which should be used to reduce signal input if in excess of 10 MV. Low impedance microphones in conjunction with an input transformer, such as McIntosh M-107, may be used on this channel.

The TAPE, TUNER and MIC channels provide flat amplification from 20 to 20,000 cycles. The Bass and Treble tone controls may be used to alter the response as desired.

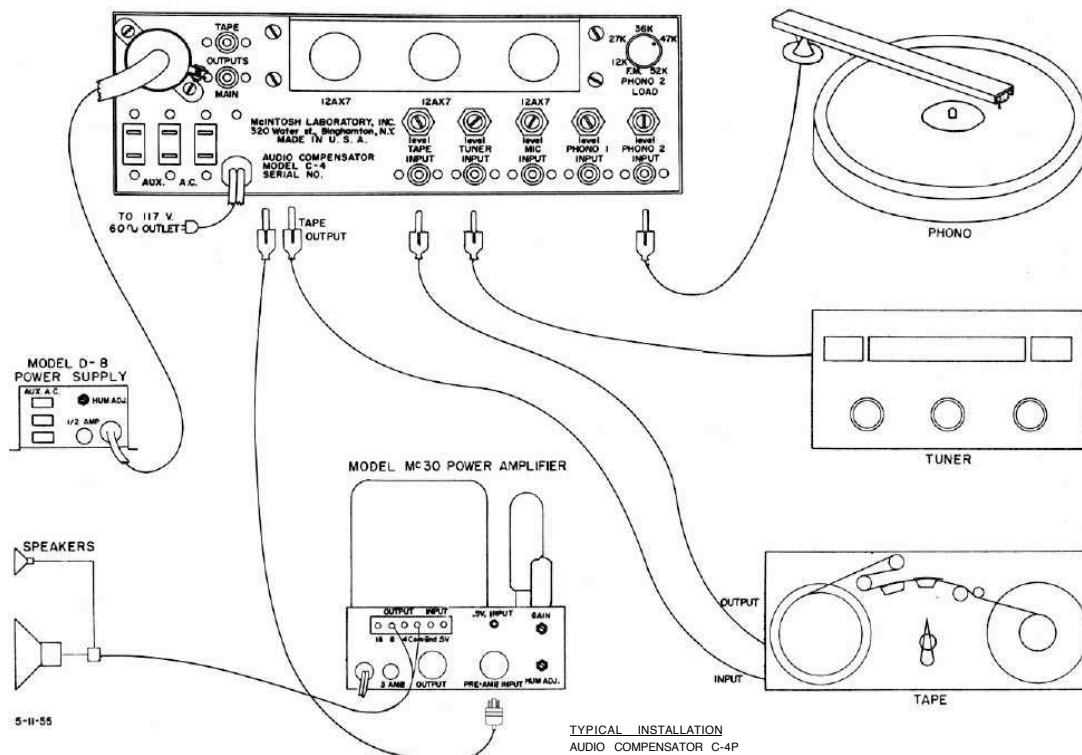
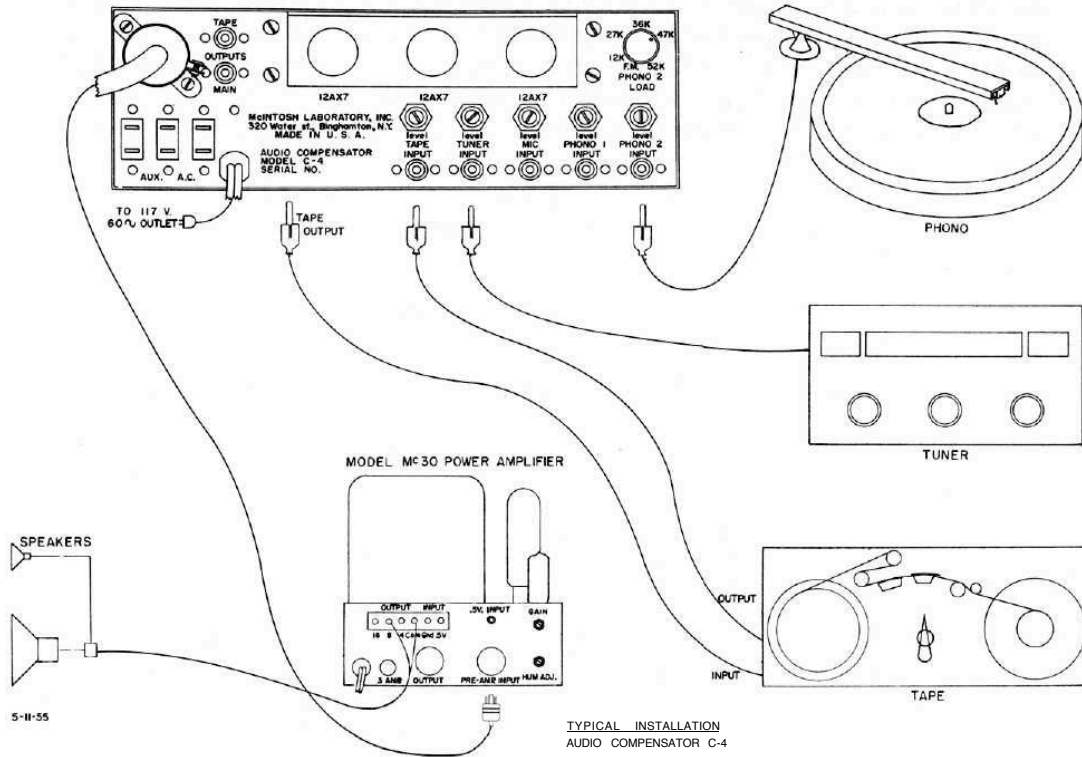

PHONO 1 Channel: This channel is equalized for use with magnetic phono-graph cartridges. A level control is provided at the rear panel to allow use of cartridges with output voltage ranging from 3 MV to 70 MV. The termination of this channel is 100K which is recommended by several cartridge manufacturers. If a lower termination is desired, a resistor may be placed across the input.

PHONO 2 Channel: This channel is the same as phono 1 channel except that a variable load control has been added. The control is calibrated from 6.8K to 52K and any termination in this range may be selected. In addition, this load control has a switch attached which operates in the counter-clockwise position. This position is labeled "FM". When the load control is placed in this position, any constant amplitude type cartridge (ceramic, crystal, FM type) may be used, allowing full use of the flexible equalization available. The level control is also effective on these cartridges.

All controls are effective on the PHONO channels.

The Compensation switch may be used to compensate recordings as recommended by the manufacturer or to adjust the compensation for a more pleasing tonal balance for the listener. The Bass and Treble tone controls are independent of the compensation switch and may be used as fine adjustments in conjunction with this switch.

The five position channel Selector switch may be used to select any of the five input channels available.

The Volume control selects the desired listening level and since it is located at the output of the Audio Compensator, the high signal to noise ratio of the unit is maintained at all levels. By properly adjusting the input potentiometers on all channels, the volume level can be held equal for all channels; the signal will remain at a constant loudness when switching from one channel to another. The master off-on switch is attached to the volume control. This switch controls the three auxiliary A.C. outlets on the rear panel of the Audio Compensator, as well as the three auxiliary A.C. outlets on the power supply of the C-4P.

GUARANTEE

We guarantee the performance of this equipment and the mechanical and electrical workmanship to be free of serious defects for a period of 90 days. This guarantee does not extend to components damaged by improper use nor does it extend to transportation to and from the factory.

McINTOSH LABORATORY INC.
320 Water Street
Binghamton, N. Y., U.S.A.

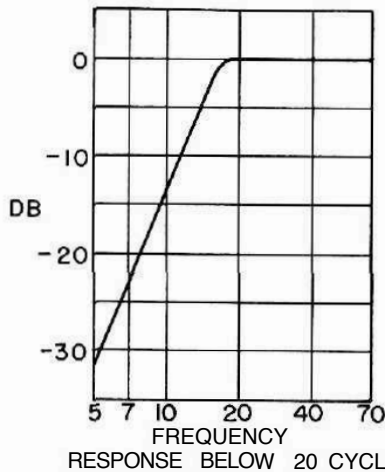
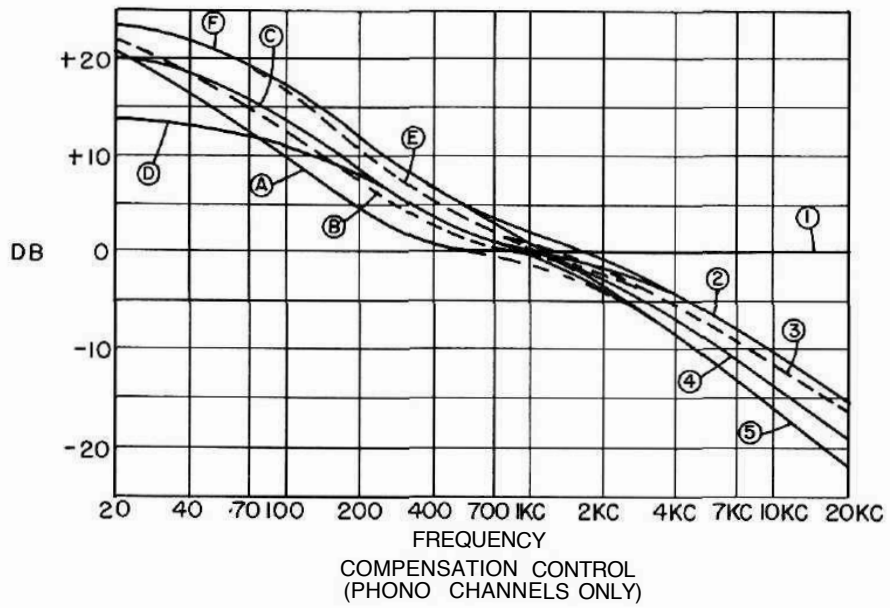
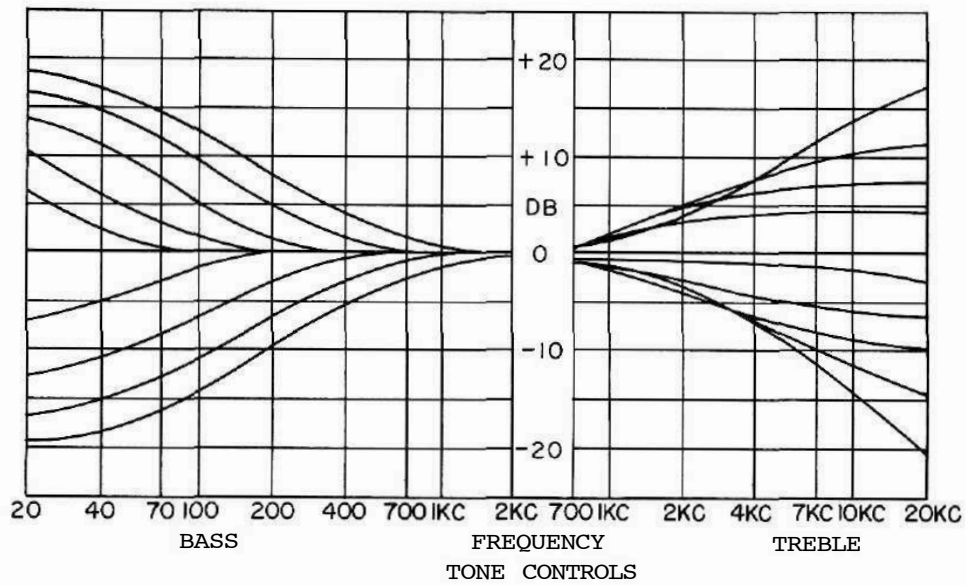

- EUR. 78 A1
- COL. 78 B5
- AES (OLD) B3
- NAB (OLD) C5
- ORTHO C4
- COL. LP D5
- LON. LP D2
- 629,16 E5
- 629,11 E3
- 800,16 F5
- 800,10 F2

NOTE: ORTHOPHONIC, R.I.A.A., NEW AES, AND NEW NART8 ARE IDENTICAL CURVES.

FREQUENCY RESPONSE CURVES FOR AUDIO COMPENSATOR, MODEL C-4

McINTOSH LABORATORY, INC
4-20-55

ALL TUBES TYPE 12AX7

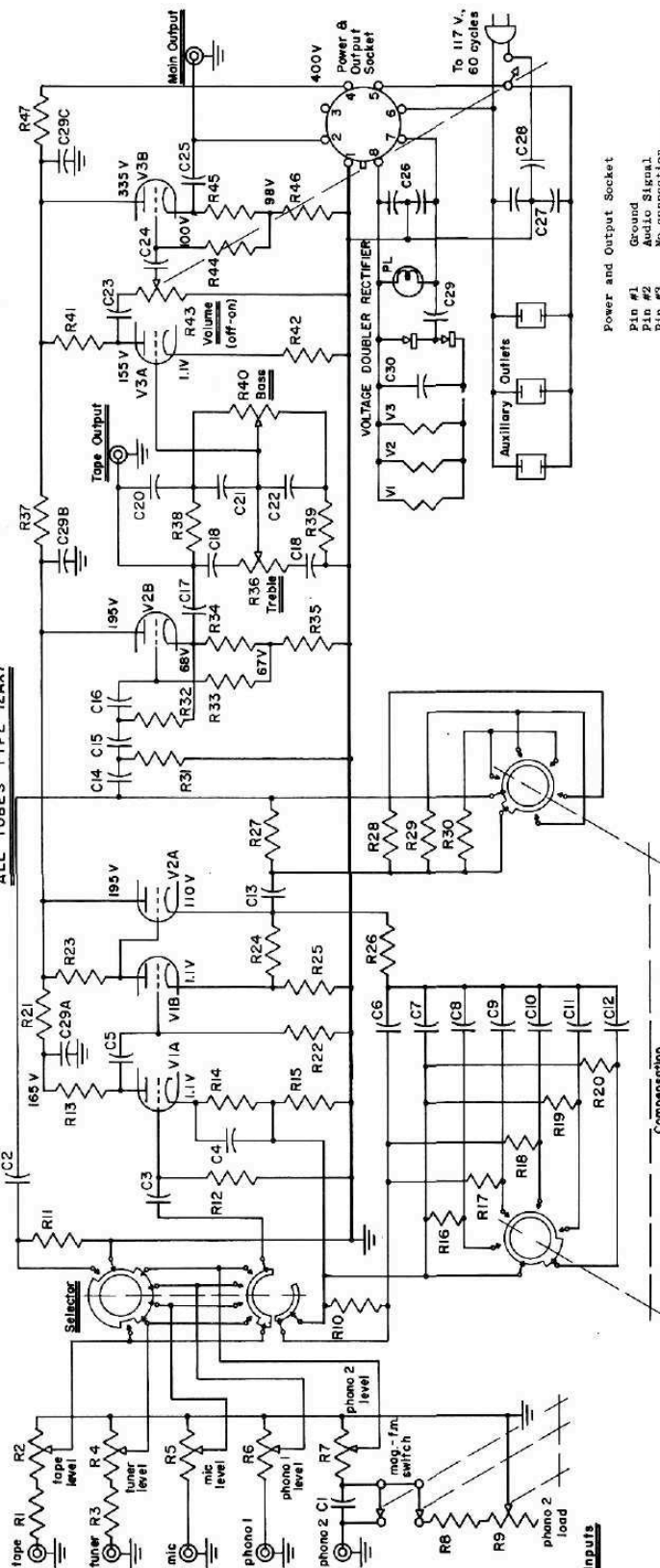

Power and Output Socket
 Pin #1 Ground
 Pin #2 Audio Signal
 Pin #3 No connection
 Pin #4 B+ (300-400V at 4 MA)
 117V, 60 cycle line for D-8 tubes not included in cable supplied (C-4)
 Pins #7&8 6.3V for filaments

- R1 560K pot
- R2 100K pot
- R3 100K pot
- R4 100K pot
- R5 100K pot
- R6 100K pot
- R7 100K pot
- R8 6.8K pot with 2W switch
- R9 100K pot with 2W switch
- R10 22K
- R11 10M
- R12 1M
- R13 220K, 1W
- R14 1.2M
- R15 5K, 1W
- R16 750 Ohms, 1W
- R17 10M
- R18 10M
- R19 560K
- R20 3.3M
- R21 10M
- R22 10M
- R23 10M
- R24 10M
- R25 10M
- R26 10M
- R27 10M
- R28 10M
- R29 10M
- R30 10M
- R31 10M
- R32 10M
- R33 10M
- R34 10M
- R35 10M
- R36 10M
- R37 10M
- R38 10M
- R39 10M
- R40 1M pot
- R41 330K
- R42 250K
- R43 250K, 1W
- R44 1.8K, 1W
- R45 1.8K
- R46 100K
- R47 100K
- R48 2 Ohms, 10W
- C1 100
- C2 .001, 200V
- C3 50MF, 6V
- C4 .033
- C5 .033
- C6 .47, 200V
- C7 .0022, 10%
- C8 .47, 10%
- C9 .001, 10%
- C10 .001, 10%
- C11 .0018, 10%
- C12 .0033, 10%
- C13 .47, 200V
- C14 10047
- C15 1000
- C16 1000
- C17 .47, 200V
- C18 .001, 10%
- C19 .01, 10%
- C20 47
- C21 .0022, 10%
- C22 .022, 10%
- C23 .033
- C24 .47, 200V
- C25 Dual .01
- C26 Dual .01
- C27 00047, 15V
- C28 2000MF, 15V
- C29 2000MF, 15V

Unless stated otherwise, component values are as follows:
 Resistance in Ohms, 10%, 1/2 watt.
 K-X 1,000, M-X 1,000,000
 Capacity less than unity in mf, 20%, 400V
 Capacity greater than unity in mmf, 20%, 500V

SERIAL NO. 6092 AND UP

MCINTOSH LABORATORY, INC
 AUDIO COMPENSATOR, MODEL C-4