

MA6500 Integrated Amplifier



MA6500

McIntosh

The lightning flash with arrowhead, within an equilateral triangle, is intended to alert the user to the presence of uninsulated "dangerous voltage" within the product's enclosure that may be of sufficient magnitude to constitute a risk of electric shock to persons.



AVIS RISQUE DE CHOC ELECTRIQUE - NE PAS OUVRIR.

The exclamation point within an equilateral triangle is intended to alert the user to the presence of important operating and maintenance (servicing) instructions in the literature accompanying the appliance.

WARNING - TO REDUCE RISK OF FIRE OR ELECTRICAL SHOCK, DO NOT EXPOSE THIS EQUIPMENT TO RAIN OR MOISTURE.

NO USER-SERVICEABLE PARTS INSIDE. REFER SERVICING TO QUALIFIED PERSONNEL.

To prevent the risk of electric shock, do not remove cover or back. No user serviceable parts inside.

IMPORTANT SAFETY INSTRUCTIONS!

PLEASE READ THEM BEFORE OPERATING THIS EQUIPMENT.

General:

1. Read these instructions.
2. Keep these instructions.
3. Heed all warnings.
4. Follow all instructions.
5. Warning: To reduce risk of fire or electrical shock, do not expose this equipment to rain or moisture. This unit is capable of producing high sound pressure levels. Continued exposure to high sound pressure levels can cause permanent hearing impairment or loss. User caution is advised and ear protection is recommended when playing at high volumes.
6. Caution: to prevent electrical shock do not use this (polarized) plug with an extension cord, receptacle or other outlet unless the blades can be fully inserted to prevent blade exposure.
Attention: pour prevenir les chocs electriques pas utiliser cette fiche polarisee avec un prolongateur, une prise de courant ou un autre sortie de courant, sauf si les lames peuvent etre inserees afond ans en laisser aucune partie a decouvert.
7. Unplug this equipment during lightning storms or when unused for long periods of time.
8. Only use attachments/accessories specified by the manufacturer.

Installation:

9. The equipment shall be installed near the AC Socket Outlet and the disconnect device shall be easily accessible.
10. Do not block any ventilation openings. Install in accordance with the manufacturer's instructions.
11. Do not install near any heat sources such as radiators, heat registers, stoves, or other equipment (including amplifiers) that produce heat.
12. Do not use this equipment near water.
13. Do not expose this equipment to dripping or splashing and ensure that no objects filled with liquids, such as vases, are placed on the equipment.
14. Use only with the cart, stand, tripod, bracket, or table specified by the manufacturer, or sold with the equipment. When a cart is used, use caution when moving the cart/equipment combination to avoid injury from tip-over.



Connection:

15. Connect this equipment only to the type of AC power source as marked on the unit.
16. Protect the power cord from being walked on or pinched particularly at plugs, convenience receptacles, and the point where they exit from the equipment.
17. Do not defeat the safety purpose of the polarized or grounding-type plug.

A polarized plug has two blades with one wider than the other. A grounding type plug has two blades and a third grounding prong. The wide blade or the third prong are provided for your safety. If the provided plug does not fit into your outlet, consult an electrician for replacement of the obsolete outlet.

18. Do not overload wall outlets, extension cords or integral convenience receptacles as this can result in a risk of fire or electric shock.
19. To completely disconnect this equipment from the AC Mains, disconnect the power supply cord plug from the AC receptacle.

Care of Equipment:

20. Clean only with a dry cloth.
21. Do not permit objects or liquids of any kind to be pushed, spilled and/or fall into the equipment through enclosure openings.
22. Unplug the power cord from the AC power outlet when left unused for a long period of time.

Repair of Equipment:

23. Refer all servicing to qualified service personnel. Servicing is required when the equipment has been damaged in any way, such as power-supply cord or plug is damaged, liquid has been spilled or objects have fallen into the equipment, the equipment has been exposed to rain or moisture, does not operate normally, or has been dropped.
24. Do not attempt to service beyond that described in the operating instructions. All other service should be referred to qualified service personnel.
25. When replacement parts are required, be sure the service technician has used replacement parts specified by McIntosh or have the same characteristics as the original part. Unauthorized substitutions may result in fire, electric shock, or other hazards.
26. Upon completion of any service or repairs to this product, ask the service technician to perform safety checks to determine that the product is in proper operating condition.

Thank You

Your decision to own this McIntosh MA6500 Integrated Amplifier ranks you at the very top among discriminating music listeners. You now have "The Best." The McIntosh dedication to "Quality," is assurance that you will receive many years of musical enjoyment from this unit.

Please take a short time to read the information in this manual. We want you to be as familiar as possible with all the features and functions of your new McIntosh.

Please Take A Moment

The serial number, purchase date and McIntosh dealer name are important to you for possible insurance claim or future service. The spaces below have been provided for you to record that information:

Serial Number: _____

Purchase Date: _____

Dealer Name: _____

Technical Assistance

If at any time you have questions about your McIntosh product, contact your McIntosh dealer who is familiar with your McIntosh equipment and any other brands that may be part of your system. If you or your dealer wish additional help concerning a suspected problem, you can receive technical assistance for all McIntosh products at:

McIntosh Laboratory, Inc.
2 Chambers Street
Binghamton, New York 13903
Phone: 607-723-1545
Fax: 607-723-3636

Customer Service

If it is determined that your McIntosh product is in need of repair, you can return it to your dealer. You can also return it to the McIntosh Laboratory Service Department. For assistance on factory repair return procedure, contact the McIntosh Service Department at:

McIntosh Laboratory, Inc.
2 Chambers Street
Binghamton, New York 13903
Phone: 607-723-3515
Fax: 607-723-1917

Table of Contents

Safety Instructions	2
Thank You and Please Take a Moment.....	3
Technical Assistance and Customer Service	3
Table of Contents and General Notes	4
Introduction	4
Performance Features	4
Dimensions	5
Installation	6
Rear Panel Connections and Switch	7
How to Connect for Loudspeakers	8
How to Connect for Audio and Data Control	9
How to Connect for Video	10
How to Connect for a Second Room	11
Front Panel Controls, Display, Indicator Push-Button and Switch	12
How to Operate	13
Remote Control Push-Buttons	16
How to Operate by Remote Control	17
Specifications	18
Packing Instruction	19

General Notes

1. Connecting Cables are available from the McIntosh Parts Department:
Data and Power Control Cable Part No. 170-202
Six foot, shielded 2 conductor, with 1/8 inch stereo mini phone plugs on each end.
2. For additional connection information, refer to the owner's manual(s) for any component(s) connected to the MA6500 Integrated Amplifier.
3. There is a built-in turn on delay which will mute the speaker outputs for approximately two seconds when the amplifier is turned on.
4. It is very important that loudspeaker cables of adequate size be used in your music system, to ensure that there will be no power loss or heating. Cable size is specified in Gauge numbers or AWG (American Wire Gauge). The smaller the Gauge number, the larger the wire size:
If your loudspeaker cables are 25 feet (7.62m) or less, use 16 Gauge (AWG) wire size or larger.
If your loudspeaker cables are 50 feet (38.1m) or less, use 14 Gauge (AWG) wire size or larger.
If your loudspeaker cables are 100 feet (76.2m) or less, use 10 Gauge (AWG) wire size or larger.
5. In the event that the MA6500 Integrated Amplifier over heats, due to improper ventilation and/or extremely high ambient temperature, the built in protection circuits will activate. The MA6500 Front Panel Power Guard LED's will both continuously indicate On and the audio output signal will be muted. When the temperature of the MA6500 has returned to a safe condition, sound will return and the Power Guard Indicators will return to normal operation.

Introduction

Your decision to own this McIntosh MA6500 Integrated Amplifier ranks you at the very top among discriminating music listeners. You now have "The Best." The McIntosh dedication to "Quality," is assurance that you will receive many years of musical enjoyment from this unit.

Please take a short time to read the information in this manual. We want you to be as familiar as possible with all the features and functions of your new McIntosh.

Performance Features

- Power Output

The MA6500 consists of two separate power amplifier channels, each capable of 200 watts and a sophisticated control center in one compact unit with less than 0.005% distortion.

- Power Guard

Both channels include the patented McIntosh Power Guard circuit that prevents the amplifier from being overdriven into clipping with its harsh distorted sound that can also damage your valuable loudspeakers.

- Electronic Input Switching

Digital Logic integrated circuits drive Electromagnetic switches on all six inputs and operating functions for reliable, noiseless, distortion free switching.

- Speaker Switching

Front panel Speaker push-buttons control two switched outputs that allow you to send signals to two separate pairs of loudspeakers.

- Sentry Monitor and Thermal Protection

McIntosh Sentry Monitor power output stage protection circuits ensure the MA6500 will have a long and trouble free operating life. Built-in thermal protection circuits guard against overheating.

- Illuminated Power Meters

The illuminated power output watt meters on the MA6500 are peak responding, and indicate the power output of the amplifier.

MA6500 Dimensions

The following dimensions can assist in determining the best location for your MA6500. There is additional information on the next page pertaining to installing the MA6500 into cabinets.

Front View of the MA6500



Rear View of the MA6500

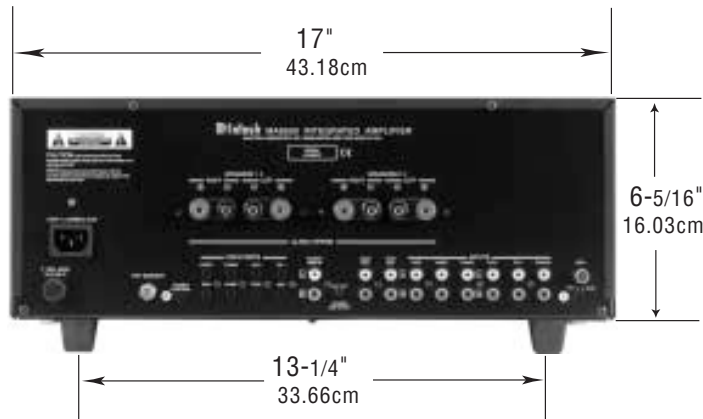

Side View of the MA6500

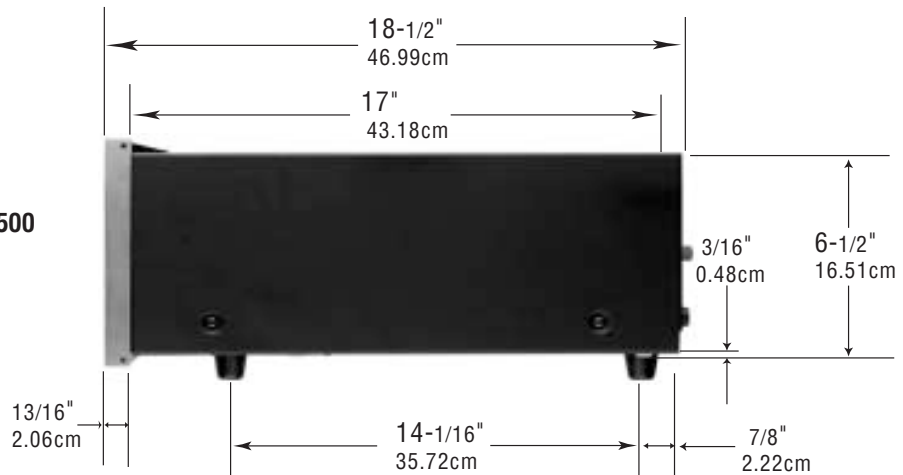

Installation

The MA6500 can be placed upright on a table or shelf, standing on its four feet. It also can be custom installed in a piece of furniture or cabinet of your choice. The four feet may be removed from the bottom of the MA6500 when it is custom installed as outlined below. The four feet together with the mounting screws should be retained for possible future use if the MA6500 is removed from the custom installation and used free standing. The required panel cutout, ventilation cutout and unit dimensions are shown.

Always provide adequate ventilation for your MA6500. Cool operation ensures the longest possible operating life for any electronic instrument. Do not install the MA6500 directly above a heat generating component such as a high powered amplifier. If all the components are installed in a single cabinet, a quiet running ventilation fan can be a definite asset in maintaining all the system components at the coolest possible operating temperature.

A custom cabinet installation should provide the following minimum spacing dimensions for cool operation. Allow at least 6 inches (15.24cm) above the top, 2 inches (3.81cm) below the bottom and 1 inch (2.54cm)

(2.54cm) on each side of the amplifier, so that airflow is not obstructed. Allow 20 inches (50.8cm) depth behind the front panel. Allow 1 inch (2.54cm) in front of the mounting panel for knob clearance. Be sure to cut out a ventilation hole in the mounting shelf according to the dimensions in the drawing.

MA6500 Front Panel Custom Cabinet Cutout

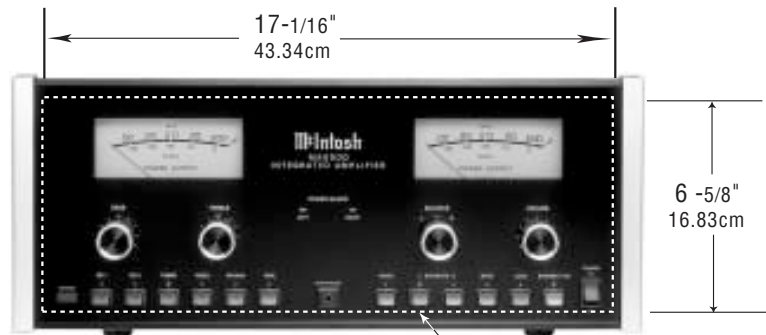

MA6500 Side View in Custom Cabinet

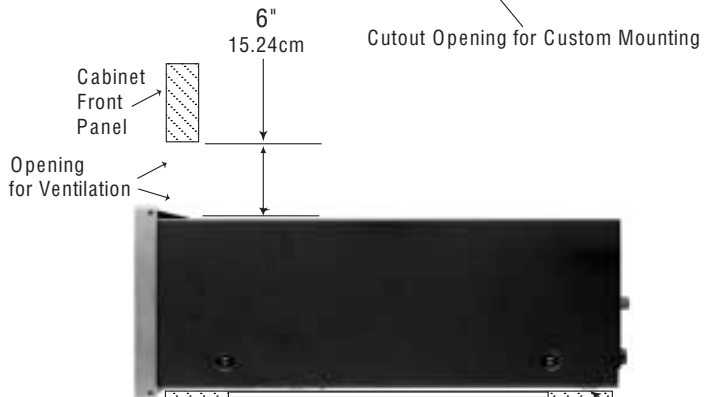

MA6500 Bottom View in Custom Cabinet

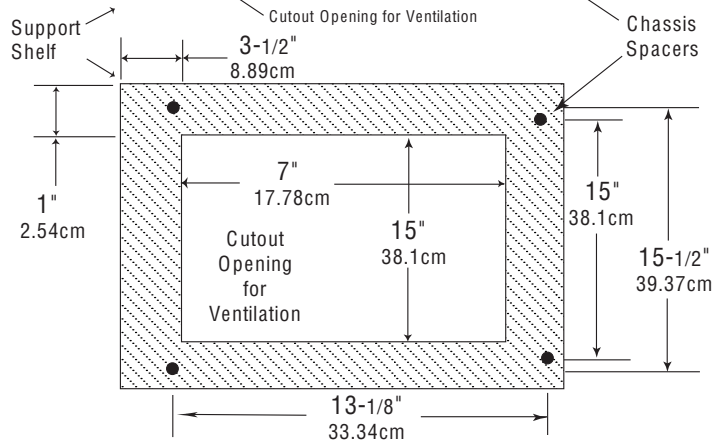

Rear Panel Connections and Switch

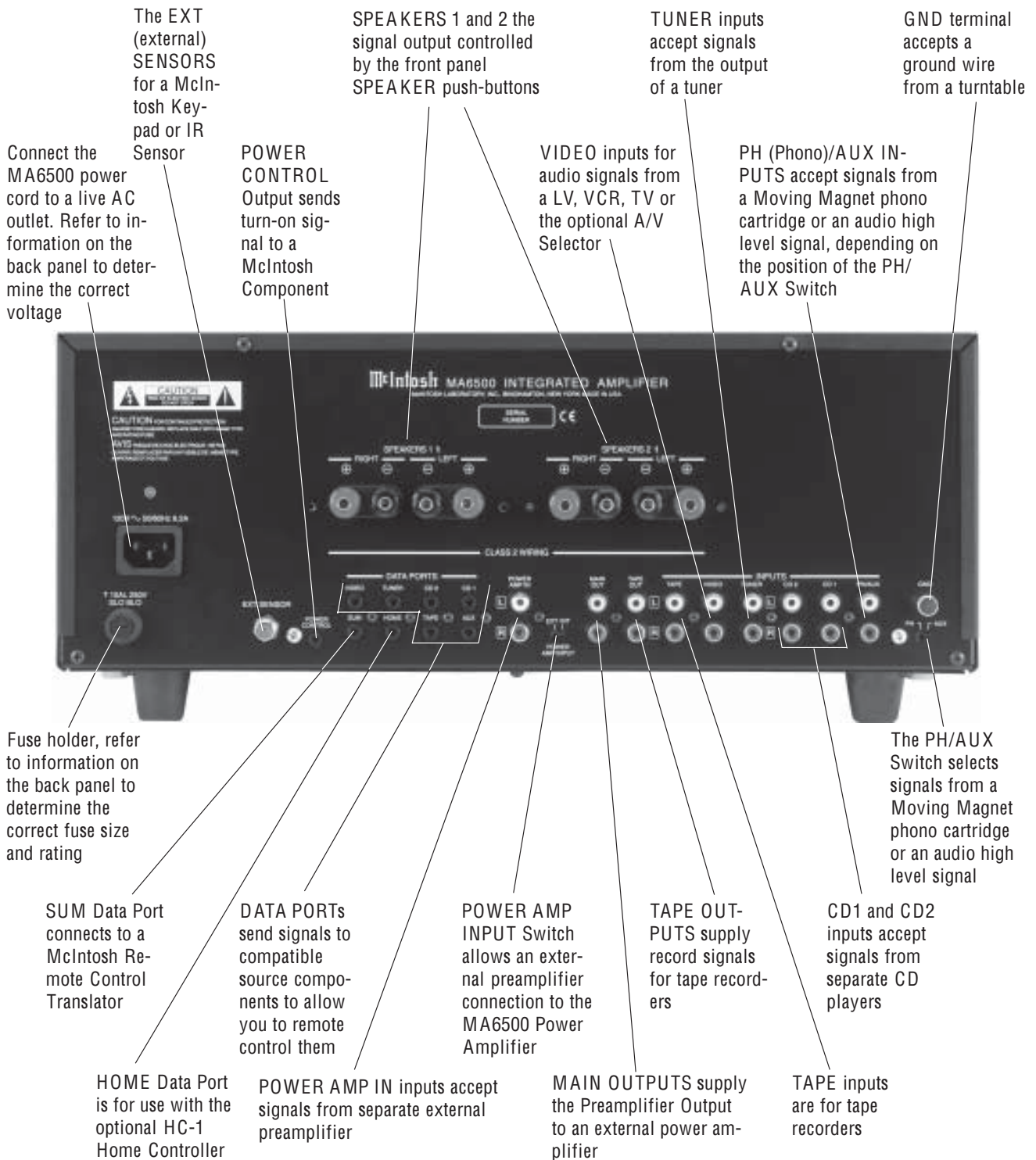

How to Connect Loudspeakers

Caution: The supplied AC Power Cord should not be connected to the Rear Panel of the MA6500 Amplifier until after the Loudspeaker Connections have been made. Failure to observe this could result in Electric Shock.

1. Prepare the Loudspeaker Hookup Cables that attach to the Amplifier by choosing one of the methods below:

Bare wire cable ends:

Carefully remove sufficient insulation from the cable ends, refer to figures 1, 2 & 3. If the cable is stranded, carefully twist the strands together as tightly as possible.

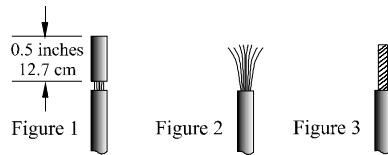

Note: If desired, the twisted ends can be tinned with solder to keep the strands together, or attach spade lug and/or banana connector.

Spade lug or prepared wire connection:

Insert the spade lug connector or prepared section of the cable end into the terminal side access hole, and tighten the terminal cap until the cable is firmly clamped into the terminal so the wires cannot slip out. Refer to figures 4, 5 & 6.

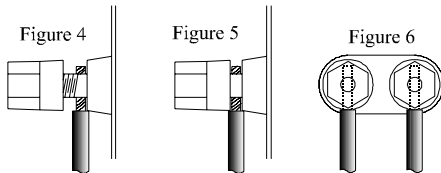

Banana plug connection:

Insert the banana plug into the hole at the top of the terminal.

Note: Banana Plugs are for use in the United States and Canada only.

2. Connect the loudspeaker cables to the appropriate terminals (SPEAKERS 1 or 2) for your loudspeakers, being careful to observe the correct polarities.
3. Install the plastic protective loudspeaker terminal covers that were supplied with your amplifier. Refer to figures 7 and 8.

WARNING: Loudspeaker terminals are hazardous live and present a risk of electric shock. For additional instruction on making Loudspeaker Connections contact your McIntosh Dealer or McIntosh Technical Support.

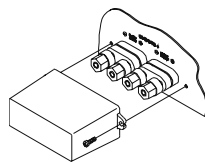

Figure 7

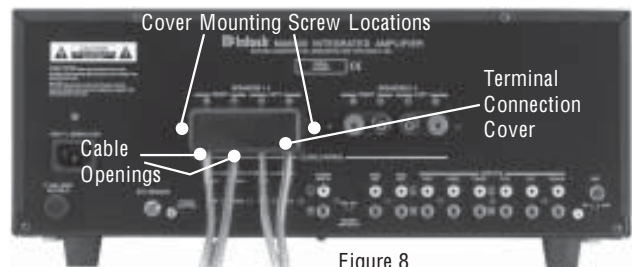
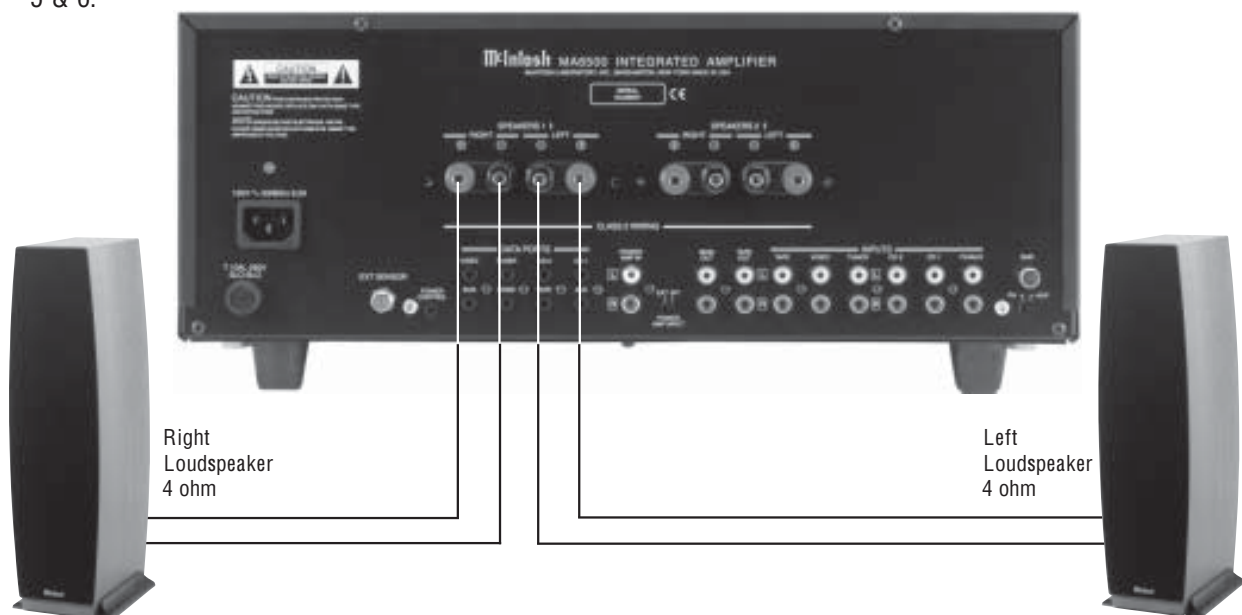
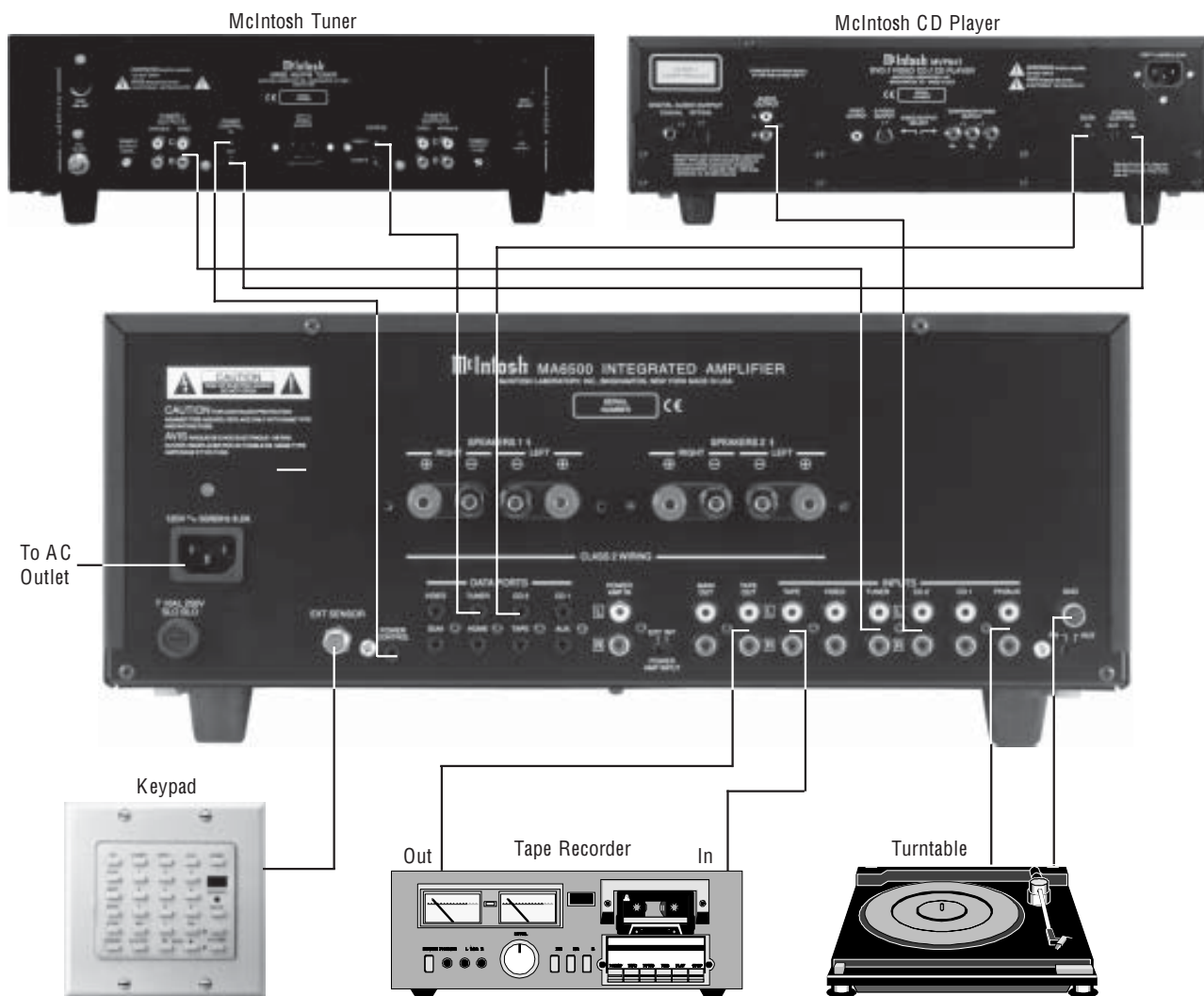

Figure 8



How to Connect Audio Components

1. Connect an Audio Cable from the McIntosh CD Player Audio Outputs to the MA6500 CD2 INPUTS.
2. Connect an Audio Cable from a McIntosh Tuner 1 Outputs to the MA6500 TUNER INPUTS.
3. Connect an Audio Cable from a Turntable to the PH/AUX INPUTS and the Turntable Ground Connection to the GND grounding post.
4. Connect an Audio Cable from the MA6500 TAPE OUTPUTS to the Record Inputs of a Tape Recorder and from the MA6500 TAPE INPUTS to a Tape Recorder Outputs.
5. Connect a Control Cable from the MA6500 POWER CONTROL ACC Jack to the Power Control In on the McIntosh Tuner.
6. Connect a Control Cable from the McIntosh Tuner Power Control Out Jack to the Power Control In jack on the McIntosh CD Player.
7. Connect a Control Cable from the MA6500 TUNER DATA PORT Jack to the McIntosh Tuner Data In (Tuner 1).
8. Connect a Control Cable from the MA6500 CD2 DATA PORT Jack to the McIntosh CD Player Data In Jack.
9. Connect an RG6 or RG59U coaxial cable from the EXTERNAL SENSOR Jack to a Keypad.
Note: A Wall Mounted IR Sensor may also be used in place of the keypad.
10. Connect the MA6500 Power Cord to a live AC outlet.



How to Connect for Video Switching

1. Connect a Data cable from the MA6500 VIDEO DATA PORT to the Audio/Video Selector Data In jack.
2. Connect the Audio/Video Selector Control Center Audio Outputs to the MA6500 VIDEO INPUTS.
3. Connect the Audio/Video Selector Video Monitor Output to a Monitor/TV.
Note: Either or both Audio/Video Selector Monitor Output(s) may be connected to the Monitor/TV.
4. Connect a McIntosh DVD/CD Player Audio Outputs to the Audio/Video Selector V-Aux Audio Inputs, the

5. Connect a Control Cable from the MA6500 POWER CONTROL ACC Jack to the Power Control In on the McIntosh DVD/CD Player.
6. Connect other video source components to the appropriate audio and video and data jacks on the Audio/Video Selector.

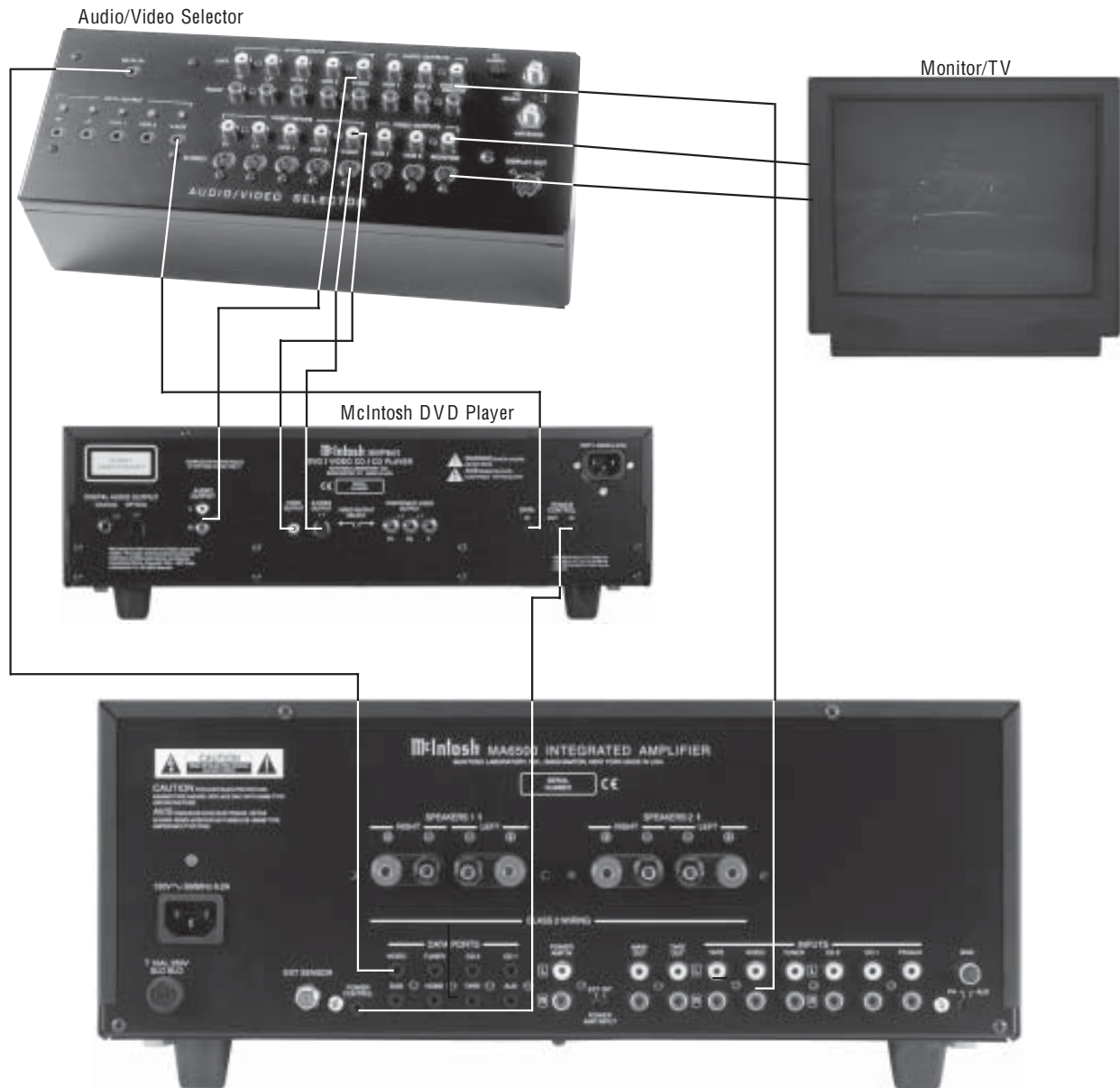

Front Panel Controls, Push-Buttons and Switch

BASS control provides 12dB boost or cut with a flat center position

TREBLE control provides 12dB boost or cut with a flat center position

METER indicates the Right Channel Power Output of the amplifier

VOLUME control allows adjustment of the listening level for both channels

METER indicates the Left Channel Power Output of the amplifier

POWER GUARD LEDs light when the amplifier's channel POWER GUARD circuit activates

The BALANCE control allows adjustment of the relative volume balance between channels

POWER switch turns all AC power completely ON or OFF



IR Sensor receives commands from a remote control

HEADPHONES jack allows connection of Stereo Headphones for private listening

SPEAKERS 1 and 2 push-buttons turn the speakers On or Off

LOUDNESS provides frequency response contour to compensate for the behavior of the human ear at softer listening levels

Select any one of the six Audio signal sources

MONO push-button combines the left and right channel signals for Mono operation

MUTE push-button mutes the listening audio

STANDBY/ON push-button turns the MA6500 ON, or OFF (Standby)

How to Operate

Power On

Press the POWER switch to ON. The Red LED above the STANDBY/ON push-button, lights to indicate the MA6500 is in Standby mode. To turn On the MA6500, press the STANDBY/ON push-button. The MUTE LED will light for approximately two seconds after turn on. Refer to figures 9 and 10.

Note: For normal operation, turn the MA6500 On and Off with the Standby/On push-button. If the amplifier is not going to be used for an extended time, turn off all AC Power with the Power Switch. You may also turn On the MA6500 by simply pressing the desired Source Selection Push-button on the Front Panel or Remote Control.

Source Selection

Select the desired source with the appropriate push-button switch on the Front Panel or Remote Control. Refer to figures 10 and 11 and page 15 for additional information.

Volume Control

Adjust the VOLUME control for the desired listening level.



Figure 9



Figure 10



Figure 11

PH/AUX Inputs

When using a phono player with a moving magnet cartridge connected to the PH/AUX inputs, set the PH AUX switch to the PH position. When using an auxiliary program source component connected to the PH/AUX inputs, set the PH AUX switch to the AUX position. Refer to figure 12.



Figure 12

Balance Control

Adjust the BALANCE control as needed to achieve approximately equal listening volume levels in each loudspeaker. Turn the BALANCE to the left to emphasize the Left Channel by reducing the level of the Right Channel. Turn the BALANCE to the right to emphasize the Right Channel by reducing the level of the Left Channel.

Bass and Treble Controls

Adjust the BASS and TREBLE controls to suit your listening preferences. The bass or treble intensity can be increased with clockwise rotation and decreased with counterclockwise rotation. All tone control circuit elements are removed from the signal path when the controls are in the center or flat position.

Loud Switch

Press the LOUD push-button to add loudness bass compensation to the volume control for improved low level listening.

Mono

Press the MONO push-button to combine left and right stereo signals to mono at the SPEAKERS 1 and 2 and HEADPHONES output.

Mute

Press the MUTE push-button to mute audio in all outputs except the HEADPHONES and TAPE OUTPUT. The MUTE LED above the push-button will flash on and off to indicate that Mute is active. To unmute audio, press MUTE, press the Remote Control Volume push-button(s) or press an Input push-button.

Speakers 1 and 2

Press SPEAKERS 1 or 2 push-buttons to switch the two pairs of speakers on or off. You can press either push-button individually, or both together. Refer to figure 13.



Figure 13

Headphones Jack

Connect a pair of dynamic headphones to the Headphones Jack for private listening. Press Mute to mute all other outputs including the amplifier connected to the loudspeakers. Refer to figure 13.

Reset of Microprocessors

In the event that the controls of the MA6500 stop functioning, push the POWER switch OFF and wait about two minutes. Then push the POWER switch ON followed by pushing the STANDBY/ON push-button. This will reset the MA6500 microprocessors and the Integrated Amplifier should be functioning normally.

Note: The above condition is usually caused by either interruptions in AC power and/or major changes that may occur in AC power line voltage.

Using a Separate Power Amplifier

There are two different ways to use a separate power amplifier with a MA6500. The first way is to use the separate amplifier instead of the MA6500 built-in power amplifier. Connect the loudspeakers to the separate power amplifier and set the rear panel POWER AMP INPUT Switch to the EXT position. Refer to figure 14.

Note: When a separate power amplifier is connected to the MA6500 and the POWER AMP INPUT Switch to the EXT position, the MA6500 Front Panel SPEAKERS Push-button Switches will no longer function.



Figure 14

The second way is to use both a separate power amplifier and the MA6500 built-in power amplifier. Connect one pair of loudspeakers to the separate power amplifier and the second/third pair to the MA6500. Set the rear panel POWER AMP INPUT Switch to the INT position. Refer to figure 14.

Note: The MA6500 VOLUME Control will affect the sound level of all the loudspeakers.

How To Make A Tape Recording

1. Select the source signal you wish to record with the appropriate Front Panel input push-button. If you wish to record from an Audio/Video source connected to the optional McIntosh Audio/Video Selector Audio/Video Selector, using the Remote Control, select the desired source connected to the McIntosh Audio/Video Selector. Refer to figure 15.



Figure 15

2. Adjust the record level using the tape recorder volume control and proceed with the recording process.
3. To listen to the tape playback of the program source just recorded, press the TAPE input push-button.

Note: The MA6500 TAPE OUTPUTS are not affected by the VOLUME or BALANCE controls.

Power Output Meters

The MA6500 Power Output Meters indicate the power delivered to the loudspeakers and are based on using 4 and 8 ohm loudspeakers. The meters respond to all the musical information being produced by the amplifier. They indicate to an accuracy of at least 95% of the power output with only a single cycle of a 2000Hz tone burst. Refer to table below.

Meter Reading	Actual Power Output (4 ohms)	Actual Power Output (8 ohms)
200	200 Watts	100 Watts
20	20 Watts	10 Watts
2.0	2 Watts	1 Watts
.20	0.2 Watts	0.1 Watts
.02	20 Milliwatts	10 Milliwatts

Remote Control Push-Buttons



Note: The Remote Control push-buttons that are blackened out are for use with other McIntosh Products.

How to Operate by Remote Control

The supplied remote control is capable of directly controlling the functions of contemporary McIntosh Source Components connected to the MA6500. Earlier McIntosh source components and other brand source components can be controlled by the MA6500 with the addition of a McIntosh Remote Control Translator (RCT).

Note: Your McIntosh Dealer can assist you with the installation and operation of the Remote Control Translator (RCT).

Mute

Press the MUTE push-button to mute audio at the SPEAKERS 1 and 2 and the MAIN OUTPUT Jacks. The TAPE OUTPUTS and HEADPHONES output are not affected by the MUTE function. The MUTE LED above the push-button will flash on and off to indicate that Mute is active. Press MUTE a second time to unmute audio.

Mono

Press the MODE push-button to combine left and right Stereo Signals to Mono at the SPEAKERS 1 and 2 and the MAIN OUTPUT Jacks.

Trim

Press the TRIM push-button to activate the Loudness Compensations circuit.

Input Source Selection

Press any of the twelve input push-buttons to select a program source. When one of the Audio/Video Inputs (SAT, LV, TV, VCR, VCR2 and DVD) are selected by remote control, the MA6500 will automatically switch to the VIDEO Input. If the Front Panel VIDEO Push-button is pressed, the source device connected to the VIDEO INPUT Jacks will be heard. When the optional McIntosh MVS Audio/Video Selector is added, multiple Audio/Video Inputs Sources, such as LV, TV, VCR, VCR2 and DVD (V-Aux), will become available by just pressing the desired program source push-button on the remote control.

CD/Tape Functions

Use these push-buttons to operate a CD player, CD changer or tape recorder.

Numbered Push-buttons

Press push-buttons 0 through 9 to access tuner station presets or CD tracks/discs.

Disc and Track

Use the DISC and TRACK push-buttons when a CD player or changer is being used.

Tuner Push-buttons

Press the AM or FM push-button to select the desired broadcast band. Press and release the Channel Up or Down push-button to move from station to station. Press and hold a Channel Up or Down push-button to move continuously from station to station. Press REVIEW to start the automatic brief audition of each of the presets stored in the tuner memory. Press REVIEW a second time to stop on a station preset and exit the Review process.

Volume

Press the Up or Down VOLUME push-button to raise or lower the listening volume level.

Note: The TAPE OUTPUTS are not affected by volume changes.

Speaker Selection

Press HOME push-button followed by the SPEAKER 1 or 2 push-buttons either separately or together, to activate the loudspeakers connected to the MA6500.

Acc On

Press ACC ON to turn the power ON to a McIntosh Disc Player.

Acc Off

Press ACC OFF to turn the power OFF to a McIntosh Disc Player.

E

Press E to perform various functions on a variety of McIntosh Components. It will also pause the playing of a disc or tape player.

Lighting

Press and release the LIGHTING push-button to momentarily illuminate the upper half of the remote control push-buttons.

Note: While the LIGHTING push-button is being depressed, the remote control will be unable to send a remote command. When the LIGHTING push-button is released the push-buttons will continue to stay illuminated for approximately three seconds thus allowing you to send the desired command. If any of the translucent push-buttons are depressed, they will continue to stay illuminated for approximately three seconds.

Frequency Response

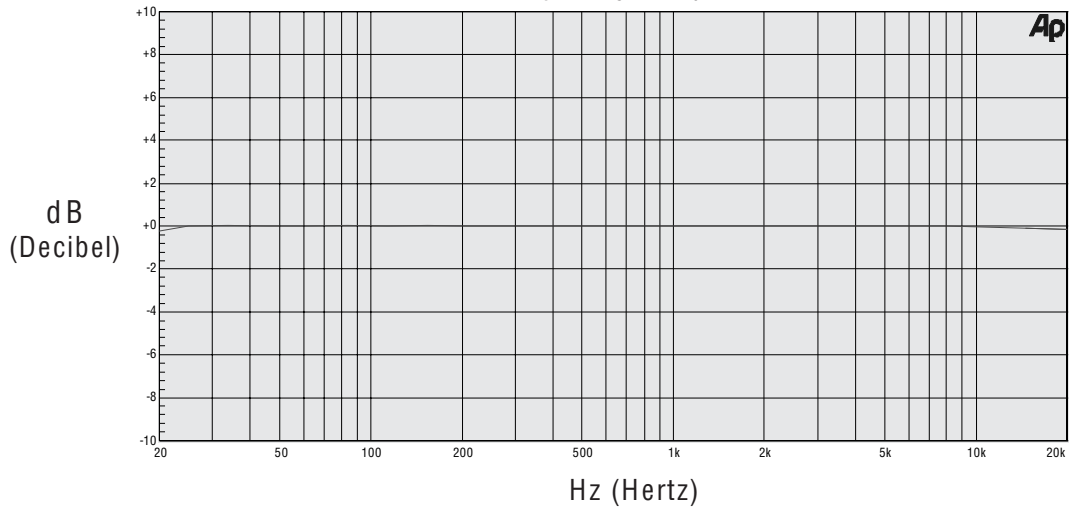

Loudness Compensation Range

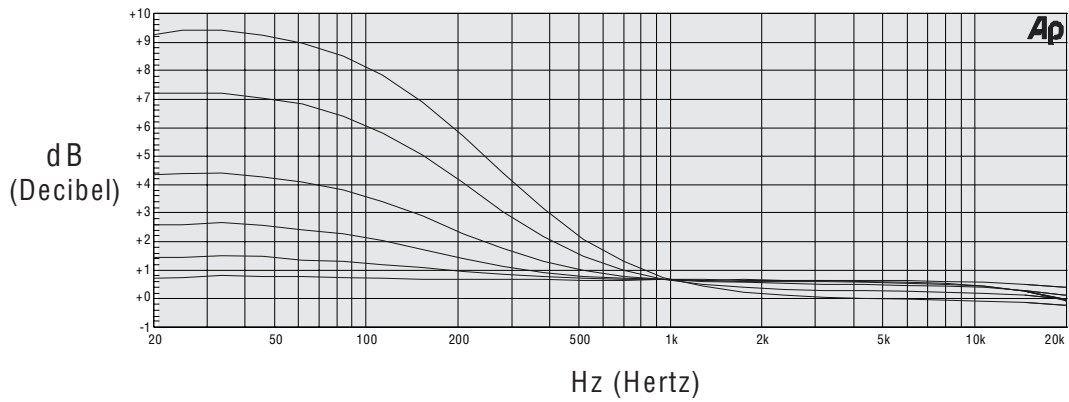

Note: The Loudness Compensation Range is a combination of the Loudness Circuitry and the Volume Control's rotational position. When the Loudness Circuit is active, the first 50% rotation of the Volume Control achieves maximum loudness compensation, as shown on the upper curve. When the Volume control is rotated beyond the 50% point, the loudness compensation is gradually reduced, as shown by the remaining curves.

Bass Control Adjustment Range

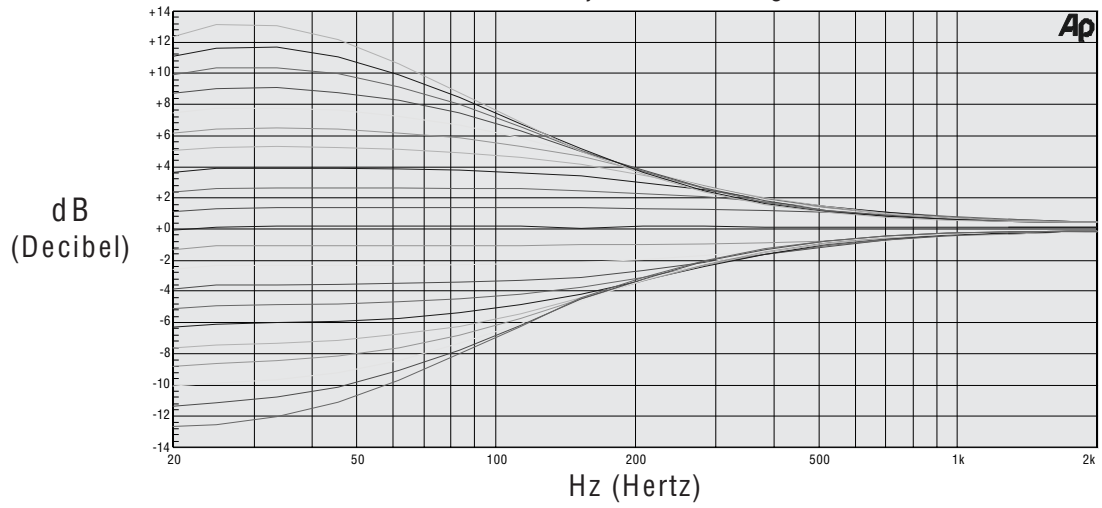

Treble Control Adjustment Range

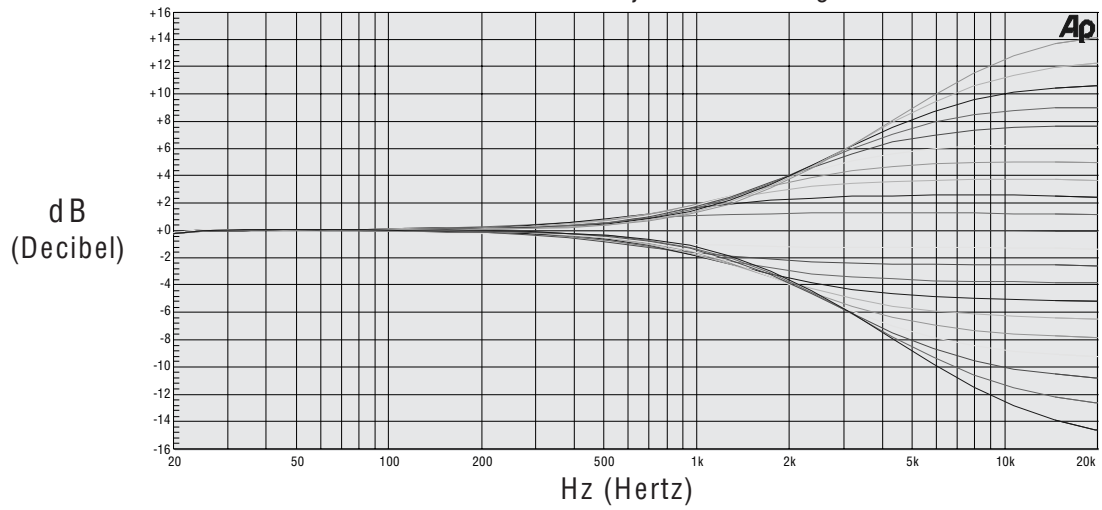

Specifications

Power Output

Minimum sine wave continuous average power output per channel, all channels operating is:
200 watts into 4 ohm load
120 watts into 8 ohm load

Rated Power Band

20Hz to 20,000Hz

Total Harmonic Distortion

Maximum Total Harmonic Distortion at any power level from 250 milliwatts to rated power output is:
0.005% for 4 or 8 ohm loads

Dynamic Headroom

2.4dB

Frequency Response

+0, -0.5dB from 20Hz to 20,000Hz
+0, -3dB from 10Hz to 100,000Hz

Sensitivity

Phono, 2.5mV for 2.5V rated output (0.5mV IHF)
High Level, 250mV for 2.5V rated output (50mV IHF)
Power Amplifier Input, 2.5V for rated output

Signal To Noise Ratio (A Weighted)

90dB (84dB IHF) below 10mV input, Phono Input
100dB (90dB IHF) below rated output, High Level
110dB below rated output, Power Amplifier

Intermodulation Distortion

Maximum Intermodulation Distortion if instantaneous peak output per channel does not exceed twice the rated output, for any combination of frequencies from 20Hz to 20,000Hz, with all channels operating is:
0.005% for 4 or 8 ohm loads

Input Impedance

Phono, 47K ohms, 65pF
High Level, 22K ohms

Maximum Input Signal

Phono, 90mV
High Level, 8V

Preamplifier Maximum Voltage Output

Phono, 8V at tape output
High Level, 8V at tape output
Main Out, 8V at preamp output

Voltage Gain

High Level to Tape: 0dB
High Level to Main: 20dB

Damping Factor

120 at 4 ohms
230 at 8 ohms

Power Requirements

100 Volts, 50/60Hz at 7.4 amps
110 Volts, 50/60Hz at 6.2 amps
120 Volts, 50/60Hz at 6.2 amps
220 Volts, 50/60Hz at 3.1 amps
230 Volts, 50/60Hz at 3.1 amps
240 Volts, 50/60Hz at 3.1 amps

Note: Refer to the rear panel of the MA6500 for the correct voltage.

Overall Dimensions

Front Panel: 17-1/2 inches (44.45cm) wide, 7-1/8 inches (18.10cm) high. Depth behind front mounting panel is 16-1/2 inches (41.91cm). Clearance required in front of the Front Panel is 1 inch (2.54cm) for knobs.

Weight

74.5 pounds (33.8 Kg) net, 92.5 pounds (41.7 Kg) in shipping carton

Packing Instructions

In the event it is necessary to repack the equipment for shipment, the equipment must be packed exactly as shown below. It is very important that the four plastic feet are attached to the bottom of the equipment. Three #10 x 2-1/4 inch screws and washers must be used to fasten the unit securely to the bottom pad and wood skid. This will ensure the proper equipment location on the bottom pad. Failure to do this will result in shipping damage.

Use the original shipping carton and interior parts only if they are all in good serviceable condition. If a shipping carton or any of the interior part(s) are needed, please call or write Customer Service Department of McIntosh Laboratory. Please see the Part List for the correct part numbers.

Quantity	Part Number	Description
1	033888	Shipping carton only
2	033887	End cap (Foam pad)
1	033697	Inside carton only
1	033725	Top Pad
1	034008	Bottom pad
2	017218	Plastic foot (spacer)
1	033699	Wood skid
2	101204	#10 x 2-1/4 inch Wood screw
2	104033	#10 x 1-3/4 inch Flat washer
4	017218	Plastic foot
4	100159	#10-32 x 3/4 inch Machine screw
4	104083	#10 x 7/16 inch Flat washer
1	048572	Sipping Carton Complete

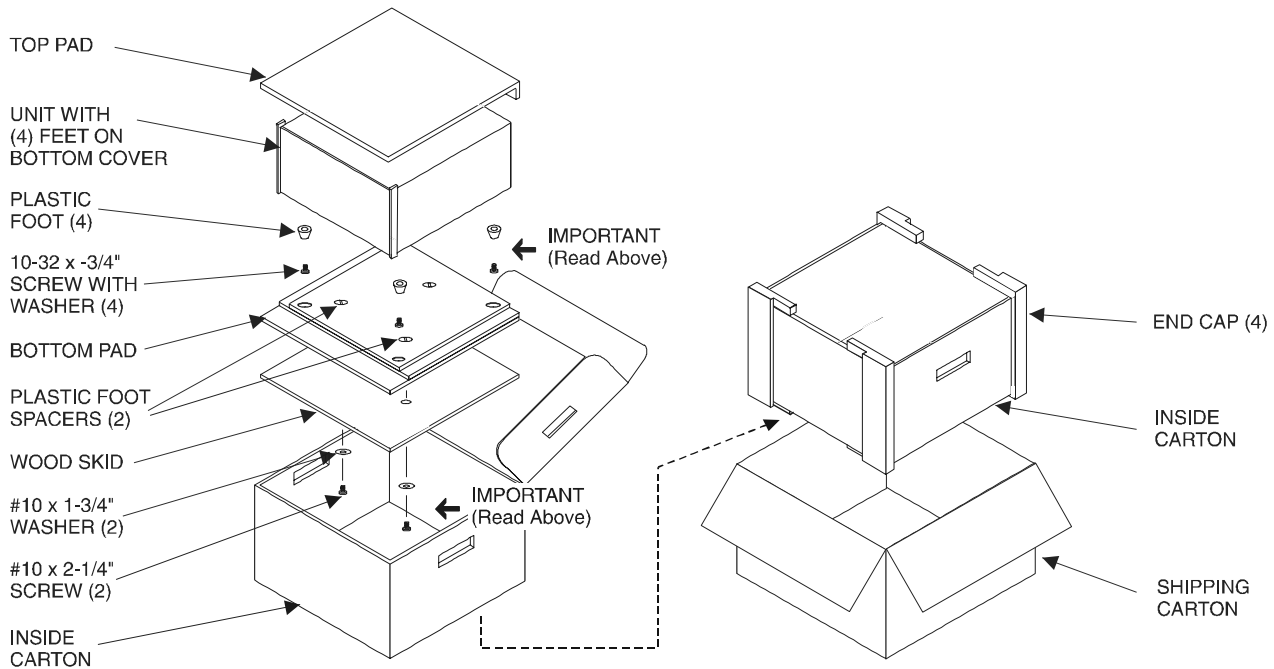

McIntosh[®]

McIntosh Laboratory, Inc.
2 Chambers Street
Binghamton, NY 13903

McIntosh Part No. 04063202