



SACD/CD Player



MCD201 Owner's Manual



The lightning flash with arrowhead, within an equilateral triangle, is intended to alert the user to the presence of uninsulated "dangerous voltage" within the product's enclosure that may be of sufficient magnitude to constitute a risk of electric shock to persons.



AVIS RISQUE DE CHOC ELECTRIQUE - NE PAS OUVRIR.

The exclamation point within an equilateral triangle is intended to alert the user to the presence of important operating and maintenance (servicing) instructions in the literature accompanying the appliance.

WARNING - TO REDUCE RISK OF FIRE OR ELECTRICAL SHOCK, DO NOT EXPOSE THIS EQUIPMENT TO RAIN OR MOISTURE.

NO USER-SERVICEABLE PARTS INSIDE. REFER SERVICING TO QUALIFIED PERSONNEL.

To prevent the risk of electric shock, do not remove cover or back. No user-serviceable parts inside.

CAUTION - Invisible Laser Radiation when open. DO NOT stare into the beam or view directly with optical instruments. Use of controls or adjustments or performance of procedures other than those specified in the Owners Manual may result in Hazardous Radiation Exposure.

**LUOKAN 1 LASERLAITE
KLASS 1 LASER APPARAT**

VAROITUS! Laitteen käyttäminen muulla kuin tassa käyttöohjeessa mainitulla tavalla saattaa altistaa käyttäjän turvallisuusluokan 1 ylittävälle näkymättömälle lasersäteilylle.

VARNING! Om apparaten används på annat sätt än i denna bruksanvisning specificerats, kan användaren utsättas för osynlig laserstrålning, som överskrider gränsen för laserklass 1.

This product incorporates an embedded **CLASS 3R Laser (IEC60825-1).**

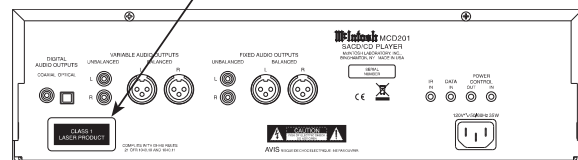
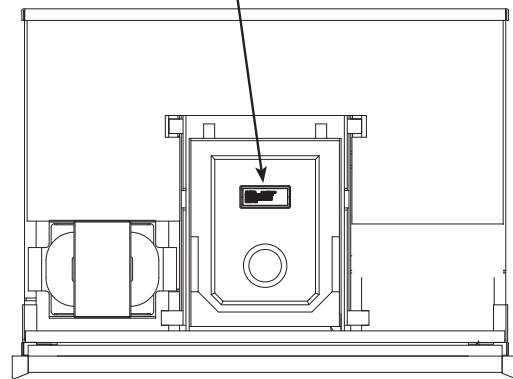
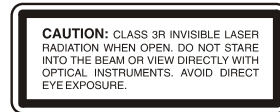

IMPORTANT SAFETY INSTRUCTIONS!

PLEASE READ THEM BEFORE OPERATING THIS EQUIPMENT.

1. Read these instructions.
2. Keep these instructions.
3. Heed all warnings.
4. Follow all instructions.
5. Do not use this apparatus near water.
6. Clean only with a dry cloth.
7. Do not block any ventilation openings. Install in accordance with the manufacturer's instructions.
8. Do not install near any heat sources such as radiators, heat registers, stoves, or other apparatus (including amplifiers) that produce heat.
9. Do not defeat the safety purpose of the polarized or grounding-type plug. A polarized plug has two blades with one wider than the other. A grounding type plug has two blades and a third grounding prong. The wide blade or the third prong are provided for your safety. If the provided plug does not fit into your outlet, consult an electrician for replacement of the obsolete outlet.
10. Protect the power cord from being walked on or pinched particularly at plugs, convenience receptacles, and the point where they exit from the apparatus.
11. Only use attachments/accessories specified by the manufacturer.
12. Use only with the cart, stand, tripod, bracket, or table specified by the manufacturer, or sold with the apparatus. When a cart is used, use caution when moving the cart/apparatus combination to avoid injury from tip-over.
13. Unplug this apparatus during lightning storms or when unused for long periods of time.
14. Refer all servicing to qualified service personnel. Servicing is required when the apparatus has been damaged in any way, such as power-supply cord or plug is damaged, liquid has been spilled or objects have fallen into the apparatus, the apparatus has been exposed to rain or moisture, does not operate normally, or has been dropped.
15. Do not expose this equipment to dripping or splashing and ensure that no objects filled with liquids, such as vases, are placed on the equipment.
16. To completely disconnect this equipment from the a.c. mains, disconnect the power supply cord plug from the a.c. receptacle.
17. The mains plug of the power supply cord shall remain readily operable.
18. Do not expose batteries to excessive heat such as sunshine, fire or the like.





Thank You

Your decision to own this McIntosh MCD201 SACD/CD Player ranks you at the very top among discriminating music listeners. You now have “The Best.” The McIntosh dedication to “Quality,” is assurance that you will receive many years of musical enjoyment from this unit. Please take a short time to read the information in this manual. We want you to be as familiar as possible with all the features and functions of your new McIntosh.

Please Take A Moment

The serial number, purchase date and McIntosh Dealer name are important to you for possible insurance claim or future service. The spaces below have been provided for you to record that information:

Serial Number: _____

Purchase Date: _____

Dealer Name: _____

Technical Assistance

If at any time you have questions about your McIntosh product, contact your McIntosh Dealer who is familiar with your McIntosh equipment and any other brands that may be part of your system. If you or your Dealer wish additional help concerning a suspected problem, you can receive technical assistance for all McIntosh products at:

McIntosh Laboratory, Inc.
2 Chambers Street
Binghamton, New York 13903
Phone: 607-723-1545
Fax: 607-724-0549

Customer Service

If it is determined that your McIntosh product is in need of repair, you can return it to your Dealer. You can also return it to the McIntosh Laboratory Service Department. For assistance on factory repair return procedure, contact the McIntosh Service Department at:

McIntosh Laboratory, Inc.
2 Chambers Street
Binghamton, New York 13903
Phone: 607-723-3515
Fax: 607-723-1917

Copyright 2005 © by McIntosh Laboratory, Inc.

Table of Contents

Safety Instructions.....	2
Thank You and Please Take a Moment.....	4
Technical Assistance and Customer Service	4
Table of Contents	4
General Information	4
Disc Information.....	5
Connector and Cable Information	5
Introduction.....	6
Performance Features	6
Dimensions	7
Installation	8

Connections:

Rear Panel Connections.....	9
How to Connect Control, Analog and Digital Audio	10
How to Connect Directly to a Power Amplifier	11

Front Panel Features:

Front Panel Displays, Controls, Push-buttons and Jack ..	12
Front Panel Information Display.....	13

Remote Control:

Remote Control Push-buttons.....	14
How to Operate by Remote Control	15

Operation:

How to Operate the MCD201	16
---------------------------------	----

Additional Information:

Specifications.....	22
Packing Instruction.....	23

General Information

1. For additional connection information, refer to the owner’s manual(s) for any component(s) connected to the MCD201 SACD/CD Player.
2. The Super Audio Compact Discs Audio Signals are converted internally from Digital to Analog.
3. A PCM version of the decoded MP3 Signal is available at the Digital Audio Outputs.

Disc Information

1. Compact Discs that are not round (e.g. Novelty discs with octagonal or heart shapes) will not play properly in the MCD201 and should not be tried, as possible damage may occur.
2. The MCD201 SACD/CD Player is designed to play all standard CD Audio Discs that conform to the Official Compact Disc Standards which is indicated by the  Symbol. It will also play most CD-R and CD-RW discs, however some recorded discs may not be able to play due to the condition of the recording.
3. CD Audio Discs recorded in the MP3 Format will play-back on the MCD201 except discs that contain multi-session recordings. Some MP3 recorded discs may not be able to play due to the condition of the recording.
4. The CD audio side of the Dual Disc does not meet the Compact Disc Digital Audio specifications found in the industry "Redbook"; the MCD201 may not read Dual Discs.
5. Several of the SACD performance features available on the MCD201 are active only if the SACD Disc includes the supporting encoded information.

Connector and Cable Information

XLR Connectors

Below is the Pin configuration for the XLR Balanced Output Connectors on the MCD201. Refer to the diagram for connection:

- PIN 1: Shield/Ground
- PIN 2: + Output
- PIN 3: - Output

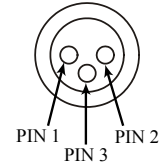

Power Control Connector

The MCD201 Power Control Input/Output Jacks receive/send Power On/Off Signals when connected to other McIntosh Components. A 1/8 inch stereo mini phone plug is used for connection to the Power Control Input/Output on the MCD201.

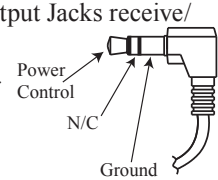

Note: The Data and Power Control Connecting Cable is available from the McIntosh Parts Department:

Data and Power Control Cable Part No. 170-202

Six foot, shielded 2 conductor, with 1/8 inch stereo mini phone plugs on each end.

Data and IR Input Port Connectors

The MCD201 Data In Port receives Remote Control Signals. A 1/8 inch stereo mini phone plug is used for connection. The IR Ports also use a 1/8 inch stereo mini phone plug and allow the connection of other brand IR Receivers to the MCD201.

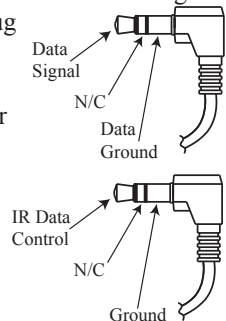



Introduction

The McIntosh MCD201 SACD/CD Player offers the latest in audio technology, providing state of the art reproduction of audio program sources. A full complement of performance features allows for the enjoyment of the SACD special audio format available on discs. Audio CDs are also reproduced with flawless realism. The advanced mechanical design of the transport ensures many years of smooth trouble free operation.

Performance Features

• **Twin Laser Pickup**

The MCD201 incorporates two laser elements, with different wavelengths, that are focused through one lens assembly. This unique design allows reading both the CD and Super Audio Compact Disc (SACD) Discs Formats.

• **Advanced Transport**

The MCD201 has a new transport with the latest in advanced digital servo for faster, quieter and accurate operation. The SACD Data is read into memory from the disc at twice the normal rate. Likewise CD Audio Data is read into memory at four times the normal rate. The fast read speeds help to insure better disc tracking and error correction processing.

• **Super Audio Disc Playback**

The MCD201 plays SACD Discs with their higher resolution sound quality.

• **Multi-Bit Digital to Analog Converter**

The 192kHz Digital to Analog Converter has a wide dynamic range and extremely low distortion.

• **Front Panel Level Control**

With headphones connected to the MCD201, the Level Control allows varying the volume level of the music. It can also be used for matching the volume level of the MCD201 with other components in the system.

• **Drive a Power Amplifier Directly**

The Variable Output Connections provide up to 6 Volts. This is more than enough signal to drive any Power Amplifier directly; forming a high quality SACD/CD Disc Playback System.

• **Balanced Outputs**

The MCD201 has both variable and fixed Balanced Outputs, permitting long cable lengths without a loss in sound quality.

• **Digital Audio Outputs**

There are Coaxial and Optical Digital Outputs for external decoding of PCM and MP3 Signals from CDs.

• **Power Control**

The Power Control Input connection provides convenient Turn-On/Off of the MCD201 when connected to a McIntosh System with Power Control. The Power Control Output connection can control a McIntosh Power Amplifier in a high quality disc playback system.

• **Full Function Remote Control**

The Remote Control provides complete control of the MCD201 operating functions including adjustment of the volume level. The push-buttons on the Remote Control are illuminated.

• **Special Power Supply**

A fully regulated Power Supply, with a special R-Core Power Transformer, ensures stable noise free operation even though the power line varies.

• **Fiber Optic Solid State Front Panel Illumination**

The Illumination of the Glass Front Panel is accomplished by the combination of custom designed Fiber Optic Light Diffusers and extra long life Light Emitting Diodes (LEDs). This provides even Front Panel Illumination and is designed to ensure the pristine beauty of the MCD201 will be retained for many years.

Dimensions

The following dimensions can assist in determining the best location for your MCD201. There is additional information on the next page pertaining to installing the MCD201 into cabinets.

Front View of the MCD201

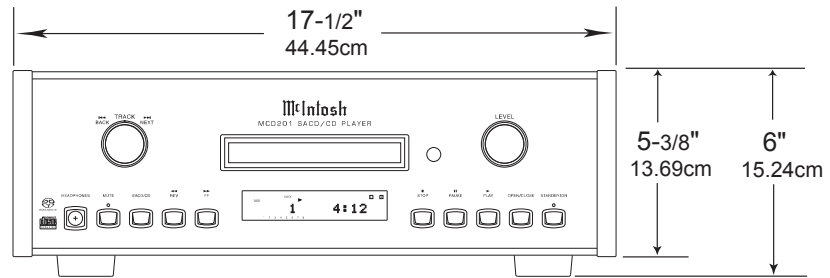

Rear View of the MCD201

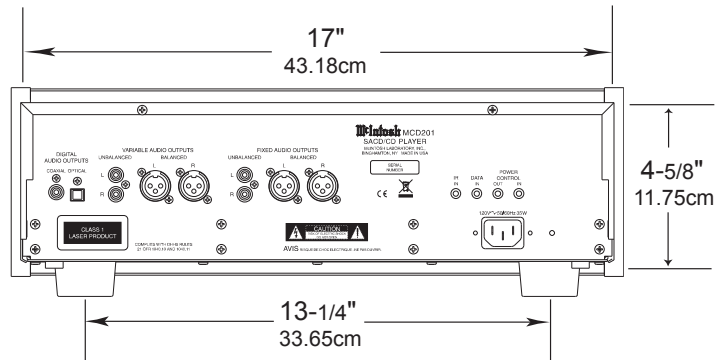

Side View of the MCD201

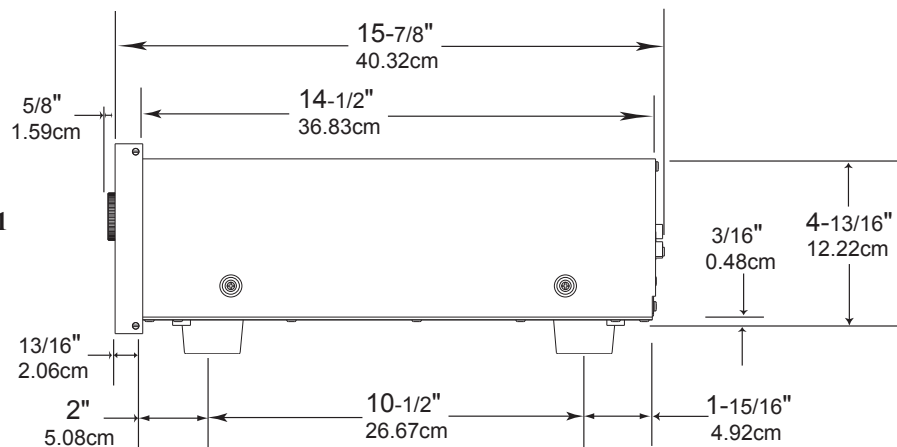



Installation

The MCD201 can be placed upright on a table or shelf, standing on its four feet. It also can be custom installed in a piece of furniture or cabinet of your choice. The four feet may be removed from the bottom of the MCD201 when it is custom installed as outlined below. The four feet together with the mounting screws should be retained for possible future use if the MCD201 is removed from the custom installation and used free standing. The required panel cutout, ventilation cutout and unit dimensions are shown. Always provide adequate ventilation for your MCD201.

Cool operation ensures the longest possible operating life for any electronic instrument. Do not install the MCD201 directly above a heat generating component such as a high powered amplifier. If all the components are installed in a single cabinet, a quiet running ventilation fan can be a definite asset in maintaining all the system components at the coolest possible operating temperature. A custom cabinet installation should provide the following minimum spacing dimensions for cool operation. Allow at least

2 inches (5.08cm) above the top, 2 inches (5.08cm) below the bottom and 1 inch (2.54cm) on each side of the Audio Control Center, so that airflow is not obstructed. Allow 17 inches (43.18cm) depth behind the front panel. Allow 1-1/8 inch (2.9cm) in front of the mounting panel for knob clearance. Be sure to cut out a ventilation hole in the mounting shelf according to the dimensions in the drawing.

MCD201 Front Panel Custom Cabinet Cutout

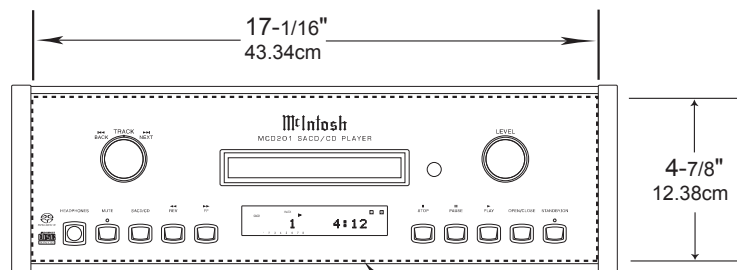

MCD201 Side View in Custom Cabinet

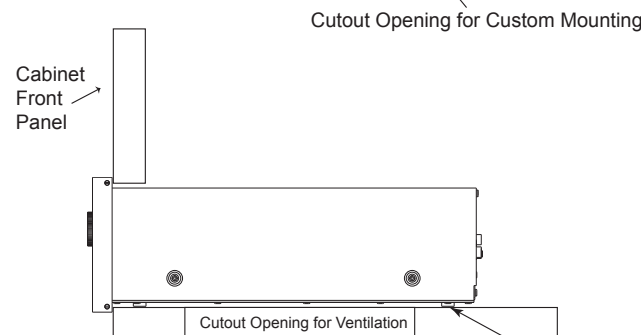

MCD201 Bottom View in Custom Cabinet

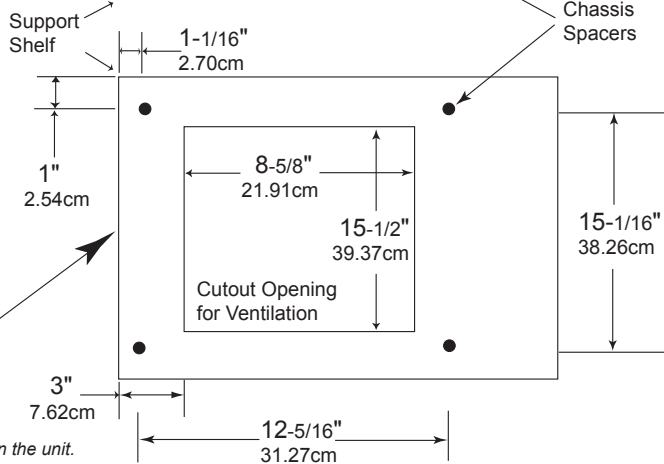

Note: Center the cutout horizontally on the unit. For purposes of clarity, the above illustration is not drawn to scale.

Rear Panel Connections

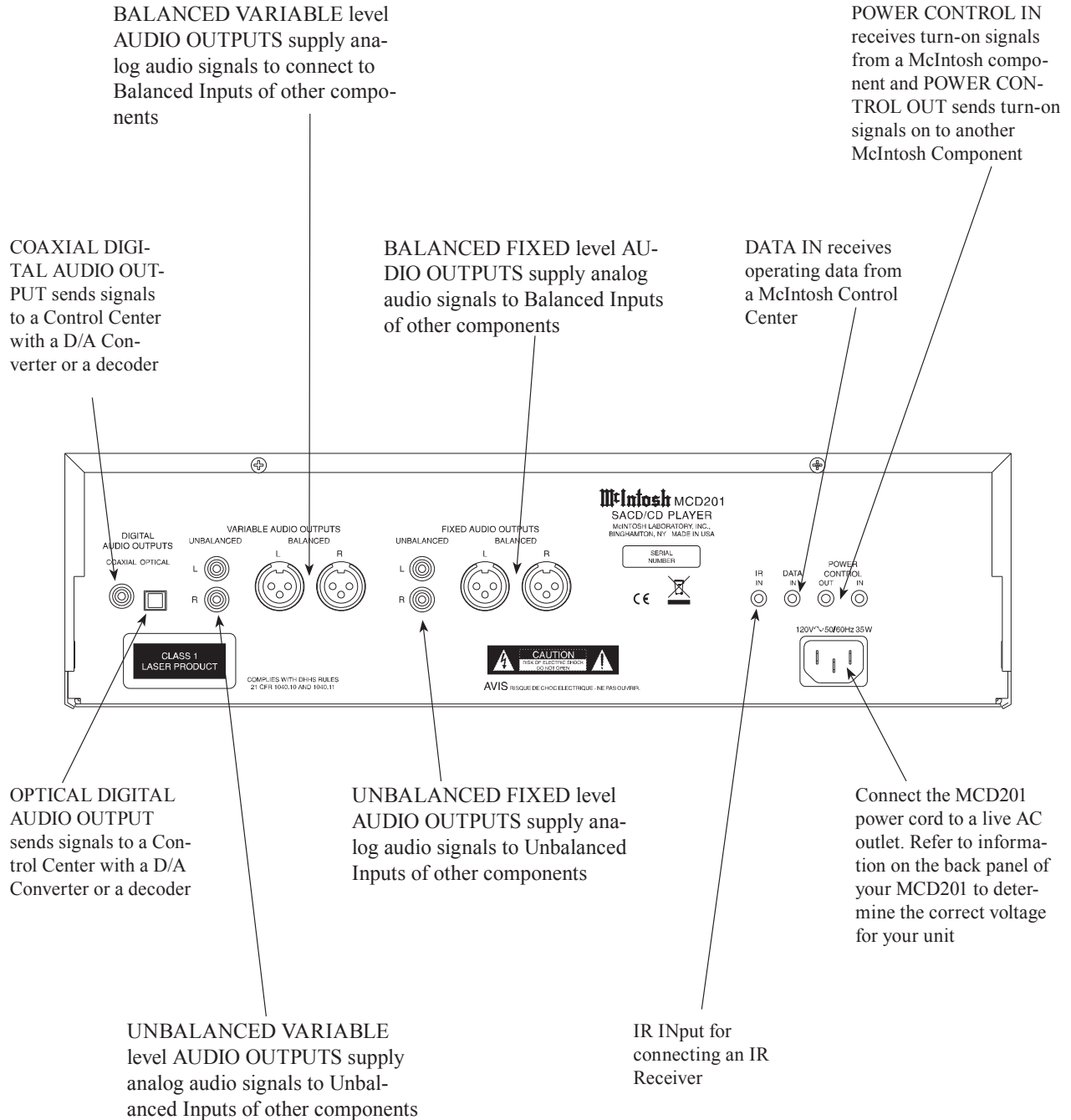



How to Connect Control, Analog and Digital Audio

1. Connect a Power Control Cable from the MCD201 POWER CONTROL IN jack to the POWER CONTROL ACC Output jack of a McIntosh Preamp/Control Center.
2. Connect a Data Cable from the MCD201 DATA IN jack to the CD2 DATA jack on the McIntosh Preamp/Control Center.
3. Connect an Optical Cable from the MCD201 OPTICAL DIGITAL AUDIO OUTPUT to the CD2 Optical DIGITAL INPUT of a McIntosh Preamp/Control Center.

Note: An optional connecting method is to use a coaxial cable from the MCD201 COAXIAL DIGITAL AUDIO OUTPUT to the Coaxial Digital Input of a McIntosh Preamp/Control Center.

4. Connect XLR Cables from the MCD201 BALANCED-FIXED AUDIO OUTPUTS to the Balanced Inputs on a McIntosh Preamp/Control Center.

Notes: 1. The Unbalanced Audio Outputs may be used instead of the Balanced Outputs.

2. The VARIABLE AUDIO OUTPUTS, Balanced or Unbalanced outputs, may be used instead of the FIXED AUDIO OUTPUTS.

5. Connect the supplied AC Power Cord between the MCD201 AC Power Cord Socket and a live AC outlet.

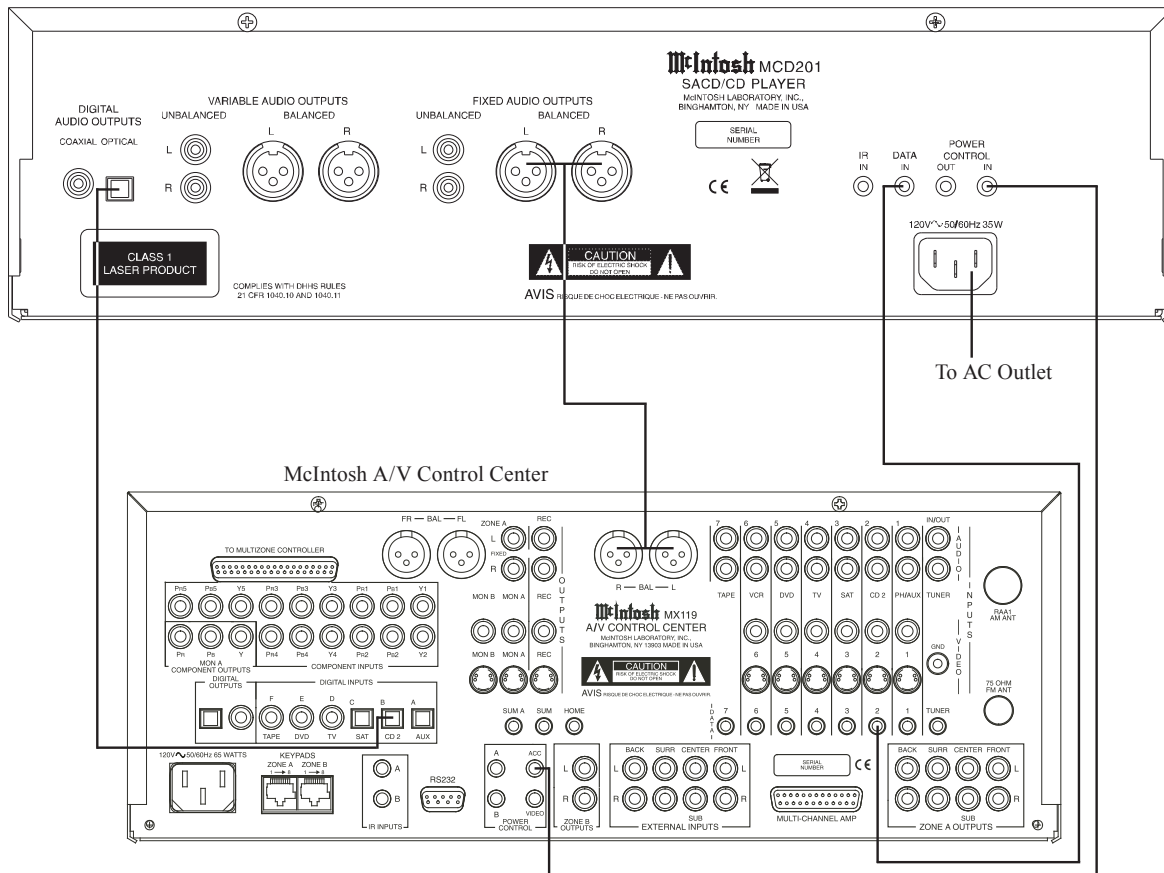

How to Connect Directly to a Power Amplifier

How to Connect Directly to a Power Amplifier

The MCD201 SACD/CD Player has Variable Output Connections and a Front Panel Level Control making it possible to form a high performance Disc Playback System. This system consists of a MCD201 directly connected to a McIntosh Power Amplifier.

1. Connect a Power Control Cable from the MCD201 POWER CONTROL OUT jack to the POWER CONTROL IN jack of a McIntosh Power Amplifier.
2. Connect XLR Cables from the MCD201 BALANCED VARIABLE AUDIO OUTPUTS to the Balanced Inputs on a McIntosh Power Amplifier.

Note: The Unbalanced Audio Outputs may be used instead of the Balanced Outputs.

3. Connect the supplied AC Power Cord between the MCD201 AC Power Cord Socket and a live AC outlet.

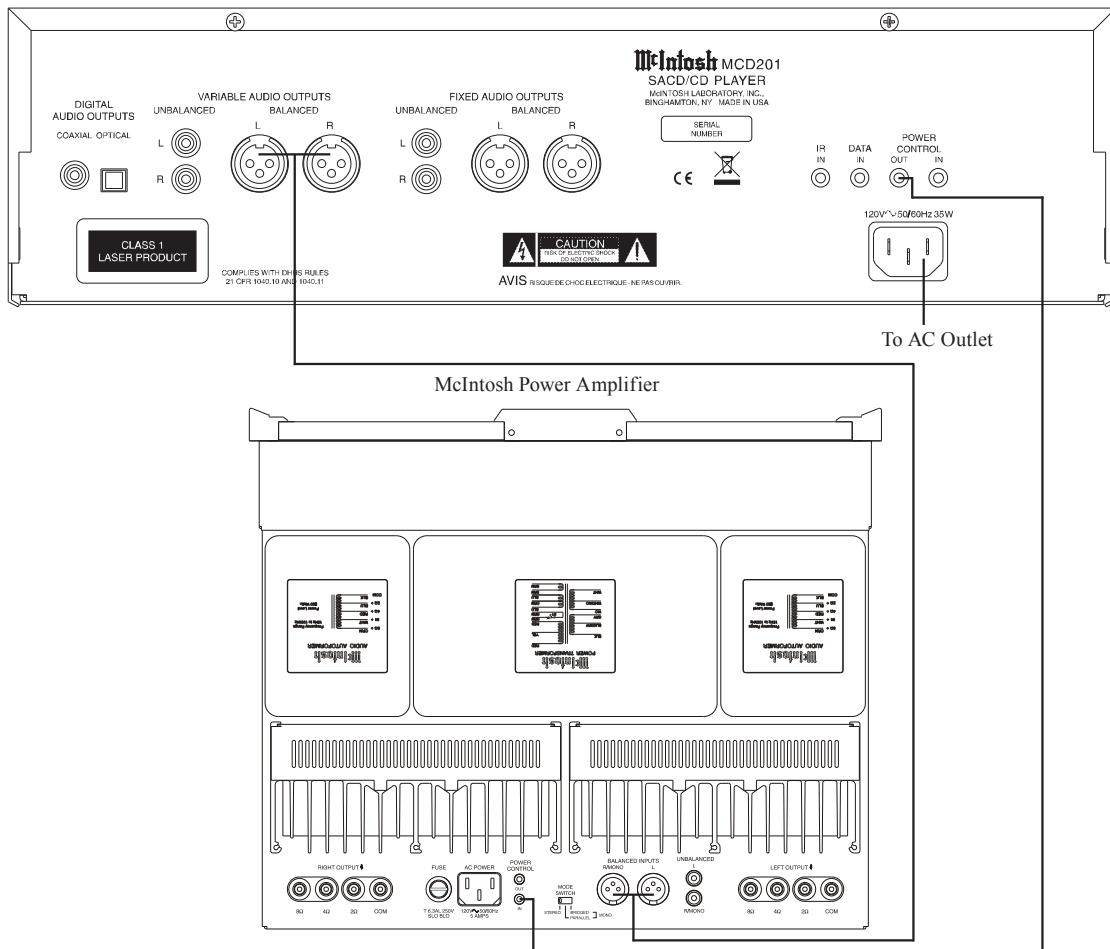



Front Panel Displays, Controls, Push-buttons and Jack

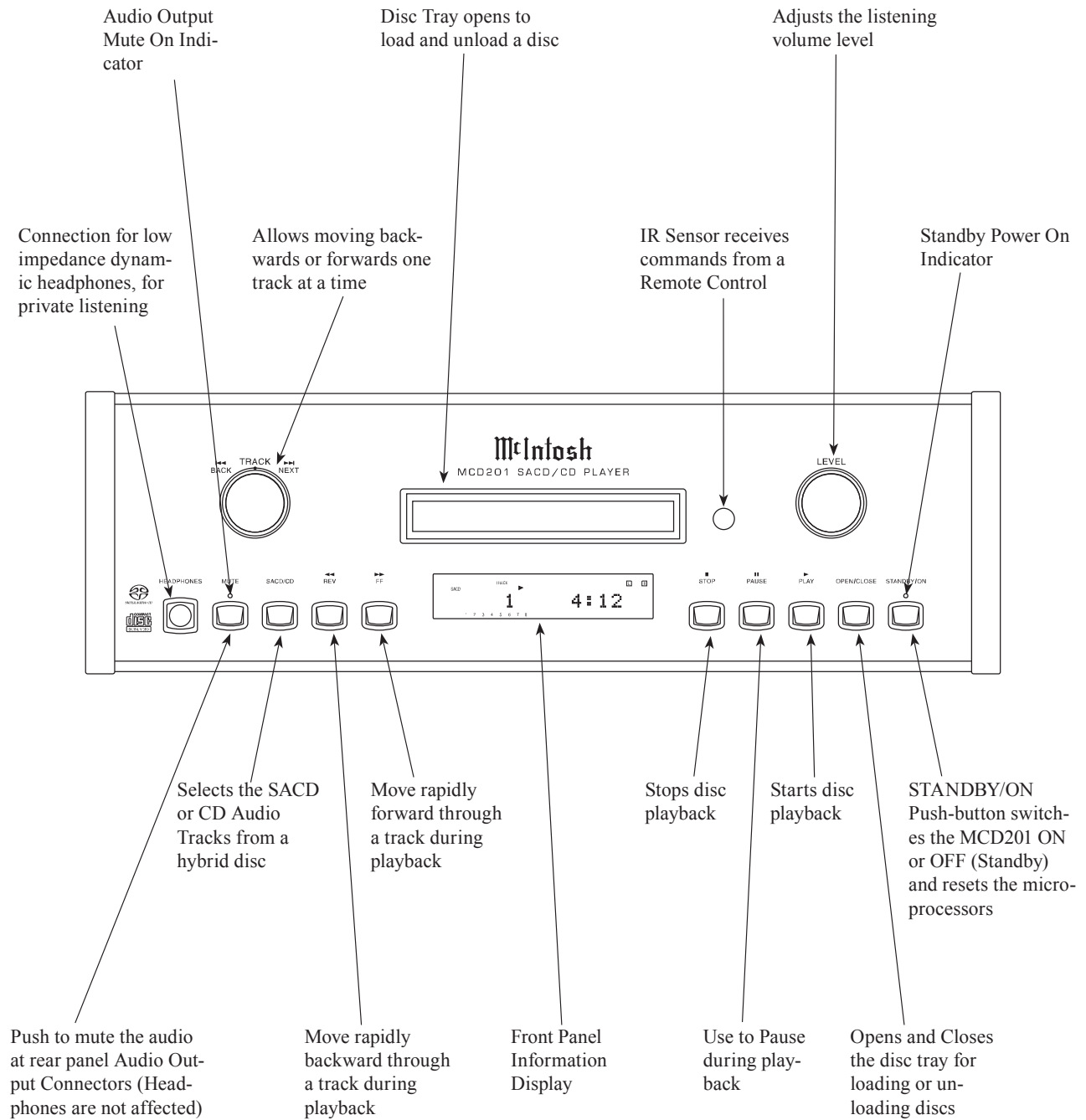

Front Panel Information Display

Indicates when the two digits below are displaying the Track Number

Indicates when in the Pause Mode

Indicates the Programming or Program Play Mode is active

Indicates the Repeat Mode selected; Repeat All (Tracks), Repeat 1 (Track) or Repeat from point A to point B in the selected Track

Indicates when the Play Mode is active

Indicates the Random Play Mode is active

Indicates the Total Time

Indicates the Remaining Time

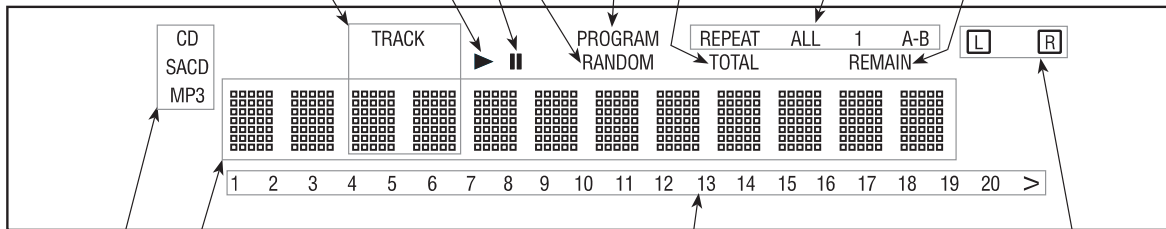

Indicates the current Track Time, Remaining Track Time, Total Disc Playing Time, Text and various other Information

Indicates the Stereo Mode

Indicates the type of disc loaded: CD, SACD or MP3

Indicates the number of tracks on the Disc and Programmed Tracks



Remote Control Push-Buttons

Access any numbered operating function

Use to Clear the last programmed track

Use to select various disc information, including time, on the Front Panel Display. It is also used to cancel the text display mode on a SACD Disc.

Starts Playback of a disc and allows moving forwards or backwards one track at a time on SACD and CD Discs

Press for random playback of tracks from SACD and CD Discs

Use to select one of various repeat modes

Use to set a starting and ending time segment on a disc for continuous repeat play

Use to review the programmed tracks from the disc on the Front Panel Information Display, while in the program mode

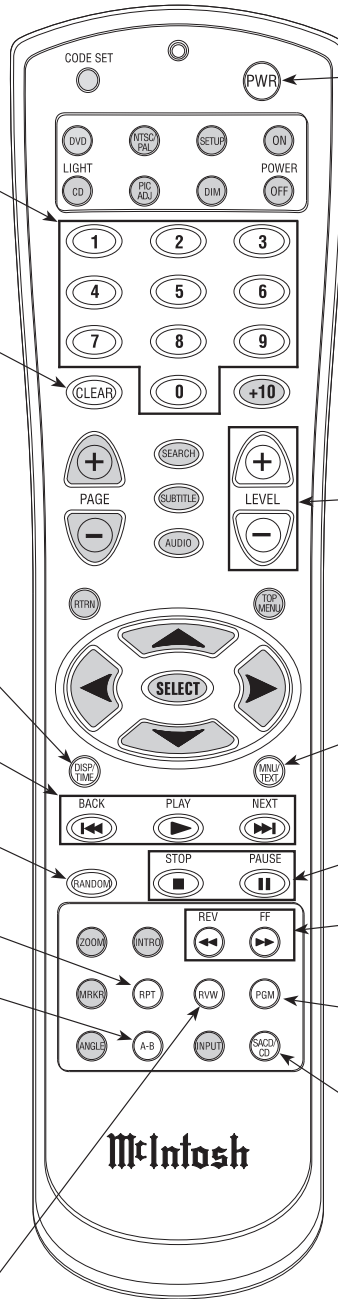

Use to toggle the power On and Off to the MCD201

Adjusts the volume level up or down

Access the Text Display Mode when playing a SACD Disc containing the information

Used to stop the disc and pause playback of the disc

Move forwards or backwards through a disc

Use to program the desired tracks on a SACD or CD disc

Use to select the SACD or CD Tracks from a hybrid disc for playback

Note: The Remote Control Push-buttons with a "grayed background" are for use with other McIntosh Products.

How to use the Remote Control

The Remote Control is capable of performing basic Operating Functions for the MCD201 SACD/CD Player.

- Notes: 1. Refer to the "How to Operate" Section of this manual for additional information using this Remote Control.*
- 2. The translucent Remote Control Push-buttons will illuminate for approximately 3 seconds when activated.*

Play

With a disc loaded, press the PLAY ► Push-button to start the disc playing.

Stop

Press the STOP ■ Push-button to stop disc playback and return to displaying the table of contents of the disc.

Numbered Push-buttons

Press 1 through 9 to directly access one of the first nine Disc Tracks using the Front Panel Information Display. For track numbers greater than 10, press the Push-button of the tens digit first and followed by the units digit. For example, to access Disc Track 23, press the 2 push-button and then the 3 push-button.

Pause

Press the PAUSE || Push-button to temporarily stop disc playback at any time. Press the PAUSE || Push-button a second time to resume playback or just press the PLAY ► Push-button.

REV and FF

Press and release REV (Reverse) ◀◀ or FF (Fast Forward) ▶▶ Push-button to start moving rapidly through a track on the disc.

Back and Next

Press the NEXT ▶▶ Push-button to move forward one track or the BACK ◀◀ Push-button to move back to the beginning of the current track playing.

Note: If the BACK ◀◀ Push-button is pressed during playback of the first three seconds of the track, the MCD201 will start playing back the previous track from the beginning.

SACD/CD

Press the select the SACD or CD Tracks from a hybrid disc for playback.

Display/Time

Press the DISPlay/TIME Push-button to access various disc times. It also used to return the Front Panel Information Display to indicating time instead of text information on a SACD Disc.

Menu/Text

Press to select the various text information on a SACD Disc such as Album, Artist and Track Titles (disc dependent).

Repeat Modes

Press the RPT (Repeat) Push-button to select either the One Track, All Tracks or cancel the Repeat Mode.

A-B Repeat

Press the A-B (Repeat) Push-button once to establish the starting point of the repeat loop and press the A-B (Repeat) Push-button a second time for the ending point, and that segment of a disc to be repeated continuously.

Program

Press the PGM (Program) to activate the Programming mode to playback only certain disc tracks in the desired order.

Review

Press the RVW (Review) Push-button to review the programmed tracks from the disc on the Front Panel Information Display, while in the program mode.

Clear

Press the CLEAR Push-button to erase a program track(s).



How to Operate the MCD201

Power On

The Red LED above the STANDBY/ON Push-button lights to indicate the MCD201 is in Standby mode. To Switch ON the MCD201, press the STANDBY/ON Push-button on the Front Panel or the PWR (Power) Push-button on the Remote Control. Refer to figures 6 and 12.

How to Load a Disc

1. Press the OPEN/CLOSE Push-button. The disc tray will slide out allowing a disc to be loaded. Refer to figure 1.
2. Press the OPEN/CLOSE Push-button and the disc tray will close. Refer to figures 6 and 2. Loading of disc's Table of Contents (number of tracks and total playing time) will be indicated on the Front Panel Information Display. Depending on the type of disc (SACD, CD or MP3), it may take up to 30 seconds to read the Table of Contents (TOC). Refer to figures 3 and 4.



Figure 1



Figure 2



Figure 3



Figure 4

Note: When a Disc is placed in the tray and the PLAY Push-button is pressed, the tray will close and the first track will start playing.

How to Play a SACD Disc

With a disc already loaded into the MCD201, press the PLAY ► Push-button on the Front Panel of the MCD201 or Remote Control. Refer to figure 5.

The Disc will start playing the first track of the SACD Layer.



Figure 5

To change from the default SACD Layer to CD Layer, with the disc stopped (press the STOP ■ Push-button if the disc is playing) press the SACD/CD Push-button on the Front Panel or Remote Control. Refer to figures 6 and 7.



Figure 7

The Player will load the CD Table of Contents (Number of tracks and Total Playing Time) at this time. To start playing the CD Layer press the PLAY ► Push-button.

Notes: 1. Changing between the layers can be accomplished at any time by performing the above procedure.

2. Some SACD Disc(s) have the ability of displaying the Album Title and Artist by pressing the MNU/TEXT Push-button after the SACD Table of Contents is read. Refer to figure 8.

3. In a similar manner, some SACD Disc(s) have the



Figure 8

ability of displaying the Track Title by pressing the MNU/TEXT Push-button after the Track has started to play. Refer to figure 9.

4. The Text Display Mode may be canceled by press-



Figure 9

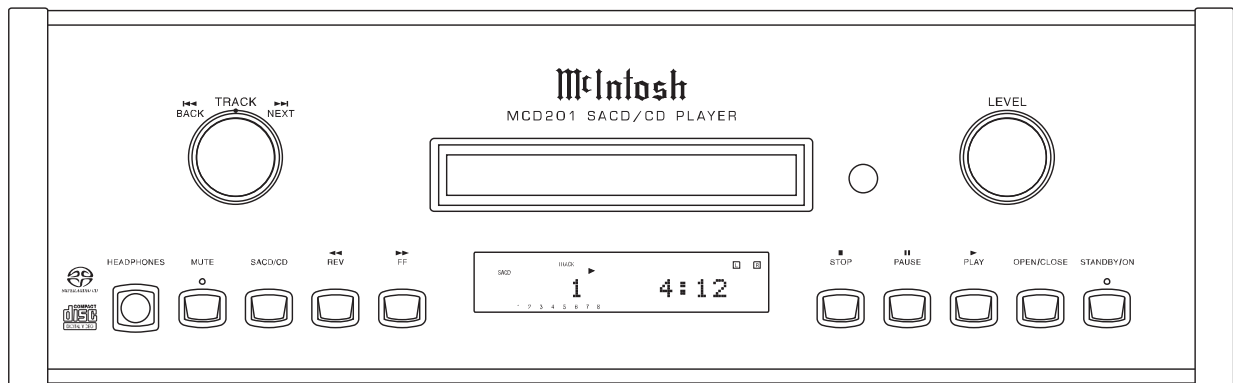

Figure 6



How to Operate the MCD201, con't

Mute

Press the MUTE Push-button to mute the audio at both the Fixed and Variable Output Connections on the Rear Panel. Refer to figure 6. The LED above the MUTE Push-button will illuminate. Pressing the MUTE Push-button a second time restores the audio at the output connections and the LED will no longer be illuminated.

Note: The Headphone Jack is not affected by the Mute Function.

Direct Track Selection

The MCD201 Front Panel Display indicates the Disc Track currently playing. Use the Remote Control NUMERIC Push-button(s) to enter the desired Track Number. Refer to pages 14 and 15 for additional information using the Remote Control.

Repeat

This allows repeating a Track or Disc on a continuous basis. Refer to figures 6 and 12.

1. Start playing the disc or the part of the disc desired to have repeated.
2. Press the RPT (Repeat) Push-button once to activate the Track Repeat (1); press the RPT Push-button twice to activate the Disc Repeat (All). Refer to figures 14 and 15.



Figure 14



Figure 15

3. To cancel the previously selected Repeat Mode, press the RPT (Repeat) Push-button until the word "REPEAT 1" or the word "REPEAT ALL" in the Front Panel Information Display is extinguished.

A-B Repeat

This feature allows continuous repeating of a specific disc segment. Refer to figures 12, 16 and 17.

1. Start playing the part of the disc you desire to have repeated.
2. Press the A-B Push-button once to enter the A (starting point) and press the same push-button a second time to enter the B (ending point).



Figure 16



Figure 17

3. To cancel A-B REPEAT function press the A-B Push-button once again. The word "REPEAT A-B" in the Front Panel Information Display will extinguished.

Note: The A-B Repeat Mode works within the track playing. Fast Forward and Reverse functions are disabled during the A-B Repeat Mode.

Random Playback

This feature allows for listening to Tracks of a Disc in a Random Order. Refer to figures 12 and 18.

Note: The MCD201 must be in STOP Mode with the Disc Loaded and the Table of Contents read before the Random Playback Mode Feature can be activated.

1. With the MCD201 in the STOP Mode press the Random Push-button. The word RANDOM should now be indicated in the Information Display.



Figure 18

2. Press the PLAY Push-button to start Random Playback. After all the tracks have been played the MCD201 will stop.

Notes:

1. To provide continuous playback of the disc, press the RPT Push-button twice to activate the Disc Repeat (All) after the Random Playback Mode has started. If Repeat (1) is selected, Random Playback Mode is canceled.
2. The BACK TRACK function is not active during the Random Playback Mode.

3. To cancel the Random Playback Mode, press the STOP Push-button, then press the Random Push-button.

Program Playback

This feature allows for the playback of programmed Tracks of a Disc in the desired order. In the example below, a Disc is programmed to play Track 6 followed by Track 4 and then Track 2.

Notes: 1. The MCD201 must be in STOP Mode with the Disc TOC (Table of Contents) read before the Program

Playback Mode Feature can be activated.

2. When programming Hybrid SACD Discs, first choose the layer (SACD or CD) so the correct TOC can be read, as some discs have different selections for the SACD and CD Tracks.

1. Press the PGM (Program) Push-button to access the Program Mode. Refer to figures 12 and 19.



Figure 19

2. Enter the first desired selection using the Numeric Push-buttons. Refer to figures 12 and 20.



Figure 20

3. In a similar manner, enter the remaining Tracks. Refer to figures 21 and 22.



Figure 21



Figure 22

Notes: 1. The CLEAR Push-button may be used to delete programmed track(s), starting with the track entered last.

2. To cancel a Program before starting playback of the Program, press the STOP ■ Push-button.

4. To start playback of the just entered program, press the PLAY ► Push-button. The Repeat Mode can be activated to provide continuous playback of the Programmed Track(s). Refer to figure 23.



Figure 23

Note: To momentarily stop playback, press the PAUSE || Push-button. To resume Program Playback press the PLAY ► Push-button.

5. To cancel the Program Playback Mode either press the STOP ■ Push-button followed by pressing the PGM (Program) Push-button or press the STOP ■ Push-button twice.
6. Once the Program Playback Mode is active, tracks may be added by first pressing the STOP ■ Push-button followed by entering the additional tracks using the Numeric Push-buttons. Then press the PLAY ► Push-button to resume Program Playback Mode.
7. If you would like to delete a track(s) once the Program Playback Mode is active, first press the STOP ■ Push-button followed by pressing the CLEAR Push-button until the desired track is removed. The MCD201 removes the last track entered first, followed by the second last track, etc. Any new tracks may be added by using the Numeric Push-buttons. Then press the PLAY ► Push-button to resume Program Playback Mode.

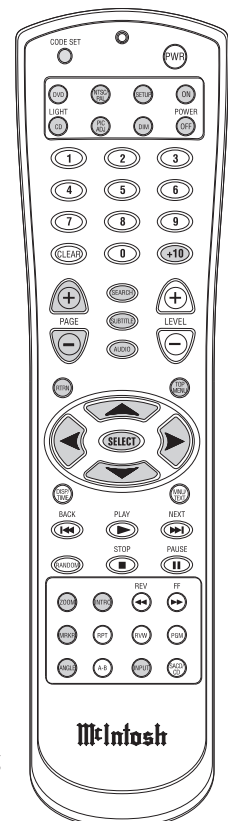

Figure 12

MP3 Disc Playback

The MCD201 has the ability of playing back MP3 encoded discs. MP3 allows more tracks on the Disc by using the technique of lossy compression applied to the original audio information. The MP3 Track has lower audio quality than the original recording. Load a MP3 disc into the MCD201. Refer to figure 24.



Figure 24

1. Press the PLAY ► Push-button to start Playback. Refer to figure 25. After all the tracks have been played the MCD201 will stop.

Note: MP3 Discs will only indicate the elapse time and remaining time for each track as it is playing.



Figure 25



How to Operate the MCD201, con't

Display Brightness

The MCD201 Front Panel Information Display has three brightness settings. To change from the default setting (brightest of the three) perform the following:

1. Press and hold the STOP ■ Push-button and rotate the TRACK Control counterclockwise, then release the control for the middle brightness setting. Refer to figure 6 on page 16.
2. With the STOP ■ Push-button still pressed in, rotate the TRACK Control counterclockwise again for the dimmest setting.
3. In a similar manner, increase the brightness by pressing and holding in the STOP ■ Push-button and rotating the TRACK Control clockwise, then release the control for the middle brightness setting. Repeat for the brightest setting.

Note: The Display Brightness will return to the default setting the next time the MCD201 is switched On.

Reset of Microprocessors

In the unlikely event the controls of the MCD201 stop functioning, the microprocessors can be reset by performing the following:

1. Press and hold in the STANDBY/ON Push-button for approximately five seconds. Refer to figure 6 on page 16.
2. When the STANDBY/ON LED is no longer illuminated, release the STANDBY/ON Push-button.
3. When the STANDBY/ON LED is illuminated press the STANDBY/ON Push-button, the MCD201 will resume normal operation.

Note: This can be performed with the MCD201 On or in the Standby Mode.

Operation in a McIntosh System

The MCD201 basic transport functions may also be controlled by using the Remote Control that comes with a McIntosh Control Center or Preamplifier. McIntosh Keypads can also be used to remotely control the basic transport functions of the MCD201. The labeling of Push-buttons on some McIntosh Remote Controls and Keypads are different from the supplied MCD201 Remote Control. Refer to the listing below and figures 26 and 27:

MCD201 Remote Control Push-button	McIntosh Remote Control/Keypad Push-button
Pause	E
SACD/CD	Review
Rev	Seek Down
FF	Seek Up
Level Up	AM
Level Down	FM

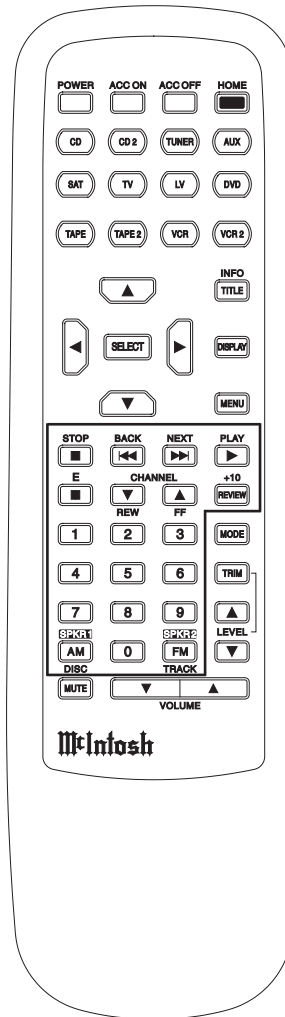

Figure 26

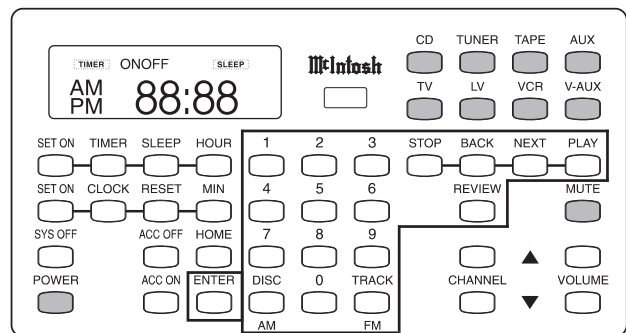
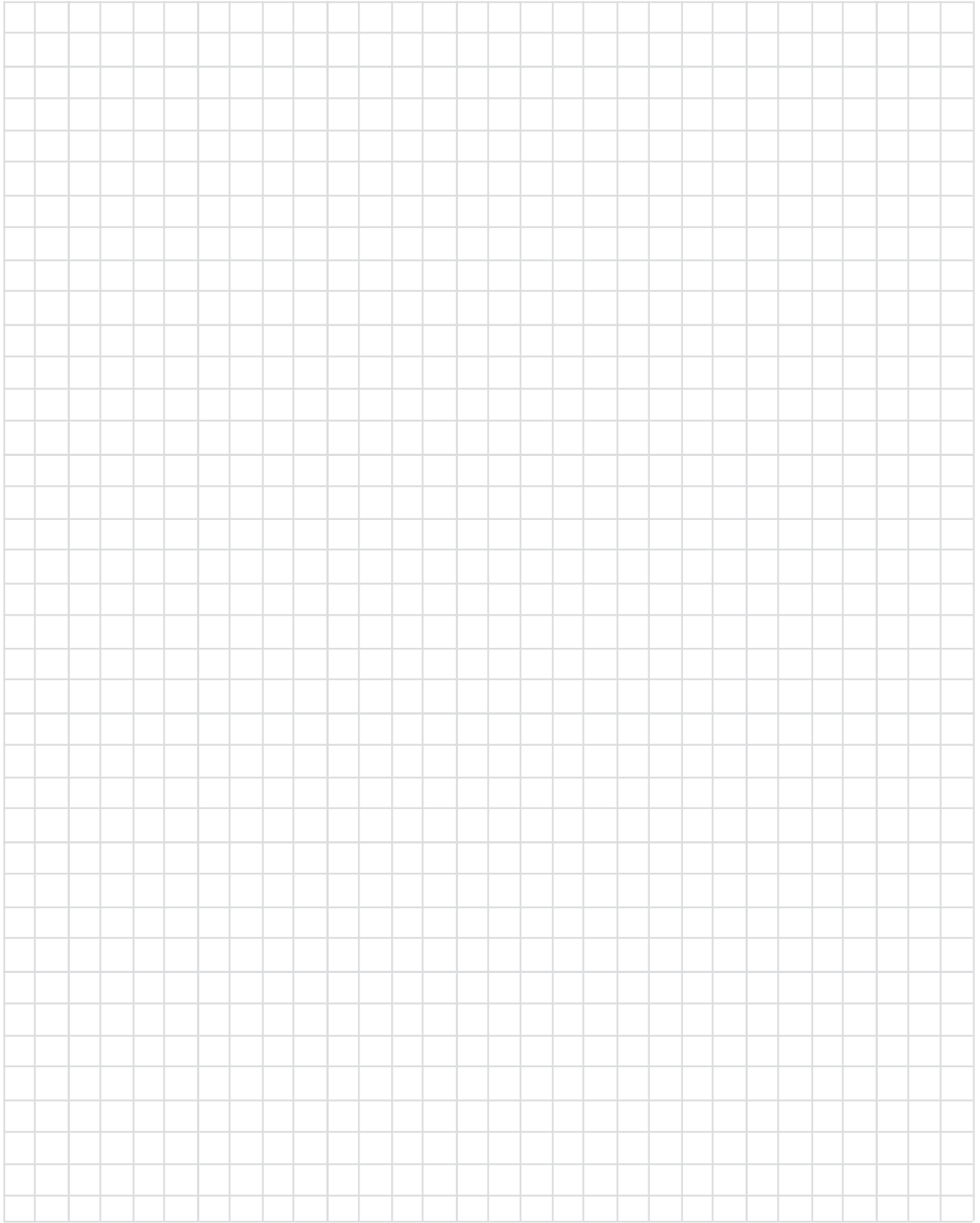

Figure 27





Audio Specifications

Fixed Output level

2.0Vrms Unbalanced
4.0Vrms Balanced

Variable Output level

0 - 6.0Vrms Unbalanced
0- 12.0Vrms Balanced

Output Impedance

600 ohms Unbalanced and Balanced

Frequency Response

4Hz to 110,000Hz, +0.5, -2dB (SACD)
4Hz to 20,000Hz, \pm .05dB (CD)

Signal to Noise Ratio

Better than 110dB (A-weighted)

Dynamic Range

Better than 100dB

Harmonic Distortion

0.002% @ 1000Hz (SACD)
0.003% @ 1000Hz (CD)

Channel Separation

Better than 98dB (1,000Hz)

General Specifications

Digital Output

Optical: - 15dbm to -21dbm (CD and MP3)
Coaxial: 0.5V p-p/75 ohm (CD and MP3)
Sampling Frequencies: 44.1kHz (CD and MP3)

Transport

Laser Beam Wavelength: 650nm (SACD)/790nm (CD)
Laser Power: CLASS IIa/CLASS I

Power Requirements

100 Volts, 50/60Hz at 35 watts
110 Volts, 50/60Hz at 35 watts
120 Volts, 50/60Hz at 35 watts
220 Volts, 50/60Hz at 35 watts
230 Volts, 50/60Hz at 35 watts
240 Volts, 50/60Hz at 35 watts

Note: Refer to the rear panel of the MCD201 for the correct voltage.

Overall Dimensions

Width is 17-1/2 inches (44.45cm)
Height is 6 inches (15.24cm)
Depth is 16-1/2 inches (41.91cm)

Note: When the Disc Tray is opened, the panel clearance required in front of mounting panel is 6-3/4 inches (17.2cm).

Weight

22.8 pounds (10.4Kg) net, 39.2 pounds (17.8Kg) in shipping carton

Shipping Carton Dimensions

Width is 26-1/2 inches (67.3cm)
Depth is 24-1/4 inches (62.2cm)
Height is 11-3/4 inches (29.9cm)

Packing Instructions

Packing Instructions

In the event it is necessary to repack the equipment for shipment, the equipment must be packed exactly as shown below. It is very important that the four plastic feet are attached to the bottom of the equipment. This will ensure the proper equipment location on the bottom pad. Failure to do this will result in shipping damage.

Use the original shipping carton and interior parts only if they are all in good serviceable condition. If a shipping carton or any of the interior part(s) are needed, please call or write Customer Service Department of McIntosh Laboratory. Refer to page 4. Please see the Part List for the correct part numbers.

Quantity	Part Number	Description
1	033838	Shipping carton only
4	033837	End cap
1	033836	Inside carton only
1	033725	Top pad
1	034301	Bottom pad
1	034037	Inner carton pad
4	017937	Plastic foot
4	100159	#10-32 x 3/4" screw
4	104083	#10-7/16" Flat washer

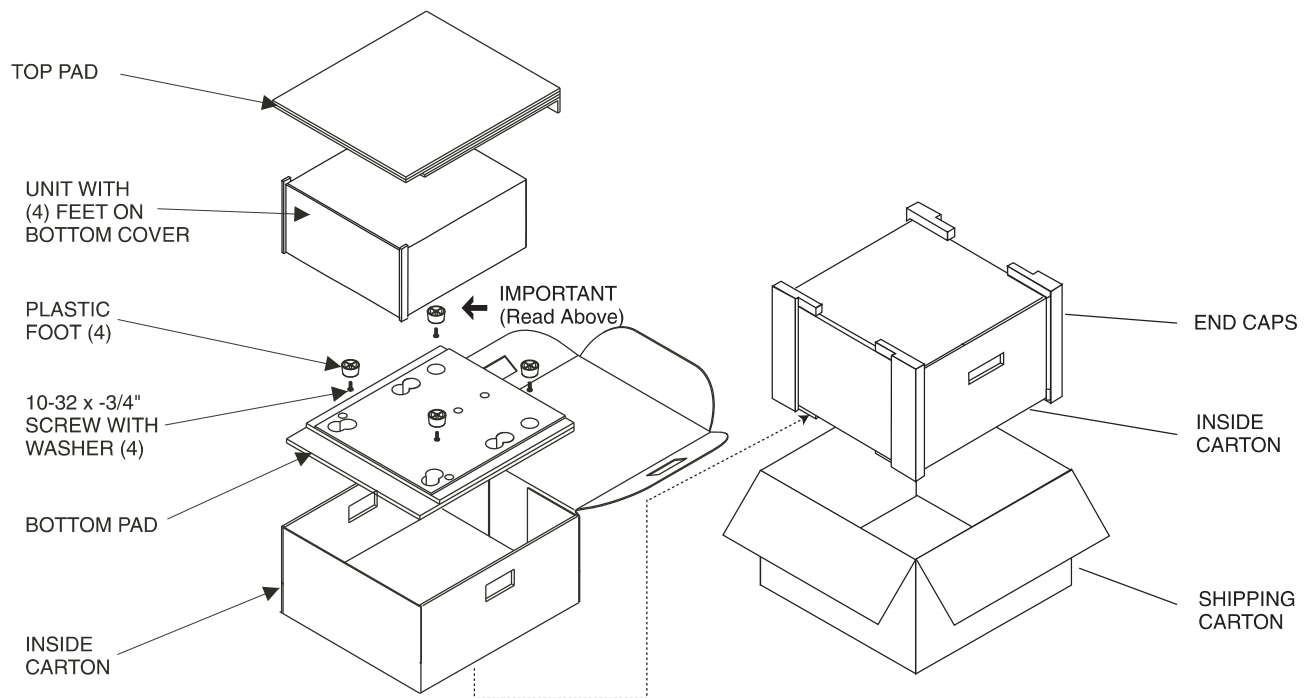



McIntosh Laboratory, Inc.
2 Chambers Street
Binghamton, NY 13903

The continuous improvement of its products is the
policy of McIntosh Laboratory Incorporated who
reserve the right to improve design without notice.
Printed in the U.S.A.

McIntosh Part No. 04095400