

**INSTRUCTION MANUAL**

**McINTOSH MODEL MR-55**

**AM-FM TUNER**

(Serial No. 1K000 and up)

**McINTOSH LABORATORY, INC.**  
**2 Chambers St. Binghamton, N. Y.**  
**U.S.A.**

The McIntosh MR-55 is a superior quality AM-FM Tuner for, use in home music systems and professional applications where distortion free reception is needed. Typical professional uses are "off the air" recording, broadcast monitor, rebroadcasting, etc.

A thorough perusal of this instruction manual will give greater enjoyment and better listening. The MR-55 is the finest tuner available and complete familiarity with its functions and operation will result in the outstanding performance you expect from a McIntosh product.

### SPECIFICATIONS:

#### AM

##### Sensitivity:

15 microvolts

##### Selectivity:

Narrow Position: 4 K.C. Bandwidth,  $\pm$  10 K.C. from center down 53 D.B.

Medium Position: 13 K.C. Bandwidth,  $\pm$  10 K.C. from center down 20 D.B.

Broad Position: 20 K.C. Bandwidth

(Measurements include R.F. and LF. circuits. Characteristics substantially unchanged over entire R.F. tuning range.)

##### A.V.C.:

Exceptionally strong; less than 4 D.B. audio output change with input changes from 10 microvolts to 100,000 microvolts.

##### Distortion:

Less than 1% at 100% modulation

##### Hum:

50 D.B. below full signal

##### Bandwidth:

LF. at 600 K.C.—20 K.C.; at 1600 K.C.—20 K.C.

R.F. at 600 K.C.—21 K.C.; at 1600 K.C.—23 K.C.

##### Audio Bandwidth:

Broad Position  $\pm$  3 D.B.—20 to 10 K.C.

Medium Position  $\pm$  3 D.B.—20 to 6.5 K.C.

Narrow Position  $\pm$  3 D.B.—20 to 2.0 K.C.

##### Sensitivity Selector:

Three Positions

##### Front End:

21 K.C. Constant bandwidth, band pass input

##### Whistle Filter:

70 D.B. rejection 10 K.C.

#### FM

##### Sensitivity:

3 Microvolts at 100% modulation ( $\pm$ \* 75 K.C. Dev.) for less than 3% total noise and distortion (Based on I.H.F.M. (proposed) standards for measuring F.M. Tuners)

##### Capture Ratio:

1 to 0.8

##### I.F. Amplifiers:

Four

I.F. Bandwidth:

200 K.C.; Flat on Top

##### I.F. Transformers:

Mechanically captive

##### Limiters:

Two; zero time constant grating-beam followed by a 0.5 microsecond pentode limiter

##### Limiter and Detector Bandwidth:

2 Megacycles

##### Frequency Response:

$\pm$  3 D.B.; 20-20,000 cycles

##### Hum:

75 D.B. below full signal

##### A.F.C.:

Separate detector; strong, distortion free, completely variable

##### Drift:

$\pm$  30 K.C. without A.F.C.; negligible with A.F.C.

##### Antenna Input Impedance:

300 ohm balanced; 72 ohm unbalanced

##### Radiation:

Substantially below F.C.C. requirements

### TUBE COMPLEMENT:

V1—6BZ7 F.M. R.F. Amplifier

V2—6BZ7 F.M. Reactor and F.M. Os

V3—6AB4 F.M. Mixer

V4—6BJ6 1st LF. Amplifier

V5—6AU6 2nd I.F. Amplifier

V6—6Bf6 3rd I.F. Amplifier

V8—6AU6 4th LF. Amplifier

V7—6AL5 A.M. Detector and A.V.C. Detector

V9—6AL5 P.M. A.V.C.

V10—6BN6 1st Limiter

V11—6AU6 2nd Limiter

V12—6AL5 F.M. Detector

V13—6BV8 AFC Detector

V14—6BA6 A.M. R.F. Amplifier

V15—6BE6 A.M. Converter

V16—6AL5 A.V.C. Clamper

V17—12AU7 Squelch Amplifier and F.M.

Metering

V18—12AU7 Audio Amplifier and Cathode

Follower

### SIZE:

4¾ Inches High x 14¾ Inches Wide x 12 Inches Deep

### WEIGHT:

Tuner Only: 17 Pounds, 3 Ounces; In Shipping Carton: 28 Pounds

## INSTALLATION INSTRUCTIONS FOR THE McINTOSH MR-55 AM-FM TUNER

The MR-55 may be mounted in its own cabinet or shelf mounted in a custom cabinet. The tuner has been designed to mount on a shelf rather than hang from the cast tuner panel. Rubber shock mounting feet have been provided to offer the optimum in mechanical isolation from extraneous vibrations.

Enclosed in the instruction manual envelope are two copies of the "TUNER PANEL CUTOUT TEMPLATE" and two copies of the "SHELF MOUNTING TEMPLATE" for mounting the MR-55. Prepare the cabinet for the mounting of the MR-55 by first cutting the wooden cabinet panel to receive the cast tuner panel.

1. On the back of the wooden cabinet panel make a vertical center line on the exact center of the area in which the tuner will mount. Extend this center line to the shelf.

2. Fold the "TUNER PANEL CUTOUT TEMPLATE" on the "FOLD LINE." The "FOLD LINE" is the line of the top of the shelf on which the tuner will mount.

3. Place the "TUNER PANEL CUTOUT TEMPLATE" in the proper location on the **inside** of the cabinet with the fold line against the shelf. The template center line should match the center line scribed on the panel in step 1.

4. In the center of the "Cutout Area" on the "Tuner Cutout Template" are two holes marked "LOCATION HOLES." Carefully and accurately drill these two holes with a 5/32 inch drill.

5. Transfer the "TUNER PANEL CUTOUT TEMPLATE" to the front of the wooden cabinet panel. Match the "LOCATION HOLES" for the proper positioning of the template. Proceed with marking the location of the six holes and the outline of the cutout on the front of the wooden cabinet panel.

**IMPORTANT: DRILL THE FOUR 3/16 INCH AND THE TWO 5/32 INCH HOLES BEFORE CUTTING OUT THE TUNER PANEL HOLE.**

The cast tuner panel has a 1/4 inch overlap to cover the edges of the cutout in cabinet panel.

Next prepare the shelf for mounting the tuner.

1. Measure the thickness of the wooden cabinet panel.

2. "FOLD LINES" have been supplied on the "SHELF CUTOUT TEMPLATE" for standard panel thickness up to one inch. Fold on correct fold line for your wooden panel thickness.

4. Place the folded edge of the template against the back of the front panel. The template center line must match the center line extended to the shelf in step #1 of the front panel cutout instructions.

5. Carefully mark the locations of the four 1/4 inch holes and the 8 by 10 1/4 inches, ventilation hole.

6. Drill and cut out the shelf.

Next prepare the MR-55 for mounting in the cabinet by removing the pressed wood shipping pallet from the bottom of the tuner.

Remove the knobs by gently pulling them toward you. Remove the felt washers.

The cast tuner panel has been attached to the tuner by two angle brackets that are for shipping purposes only. These are removed by unscrewing the four screws (two on each side) that hold the angle brackets to the tuner chassis. After removing these four screws the tuner panel can be slipped off over the knob shafts.

After removing the tuner panel lay it face down on a protected surface for the following operations.

Remove the four 6/32 screws (one on each corner) that hold the two shipping brackets to the tuner panel

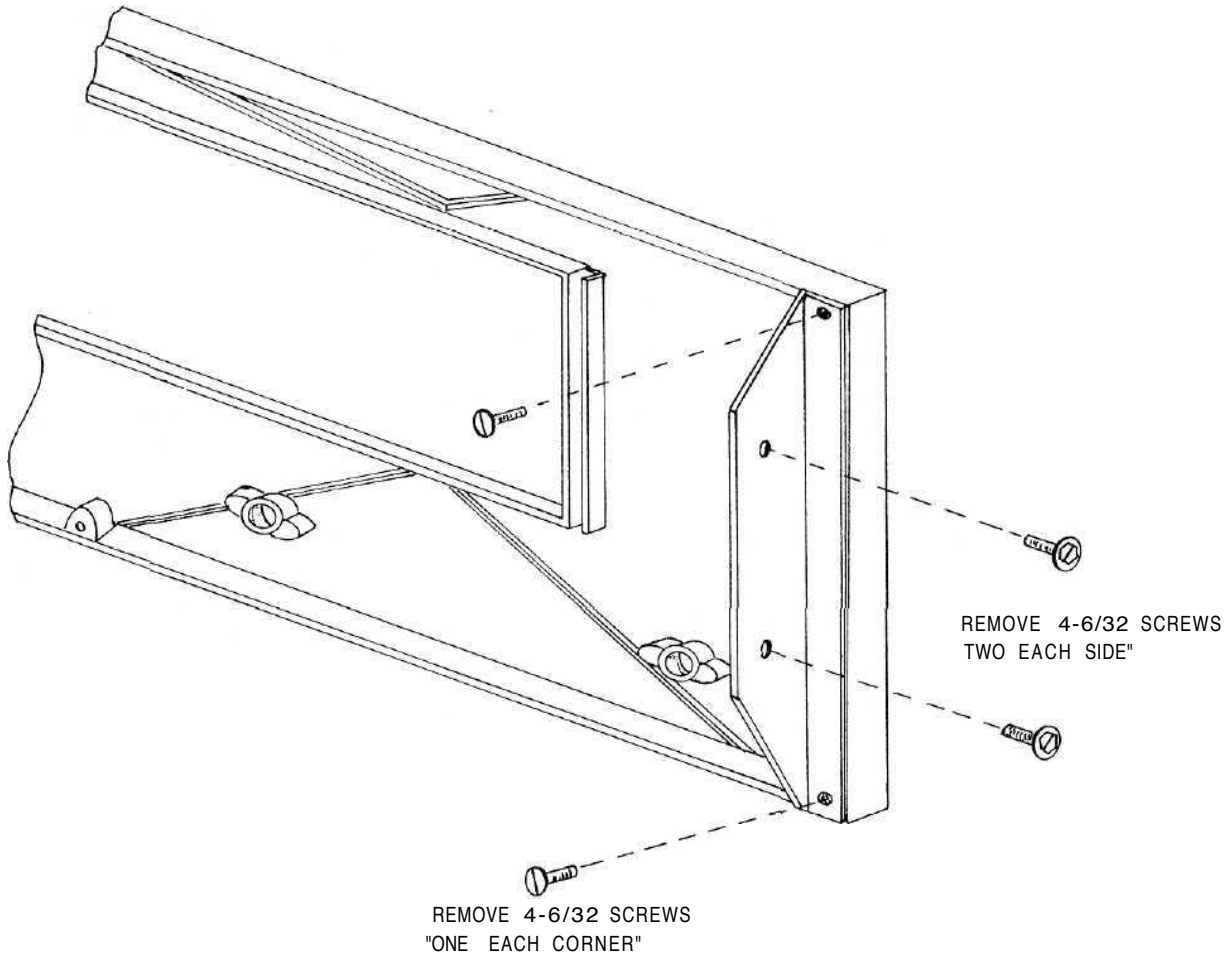

In the parts bag are six 6/32 x 1 1/4 inches threaded rods. Install these in the six drilled and tapped holes in the back of the tuner panel.

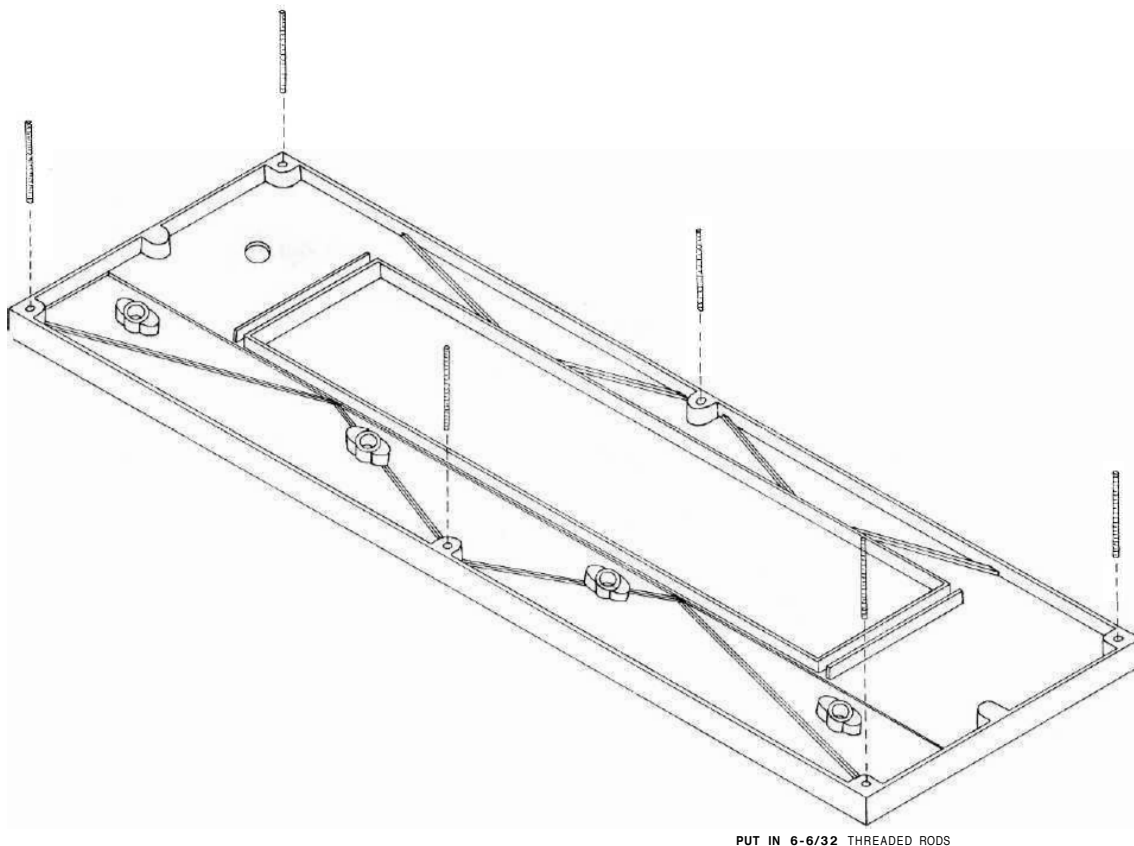

PUT IN 6-6/32 THREADED RODS

The tuner panel is now ready to be attached to the cabinet. The six threaded rods are inserted through the two 5/32 inch and the four 3/16 inch holes in the cabinet panel. Secure the tuner panel to the cabinet panel by installing on the rods the 6/32 "KEP" nuts supplied in the parts bag. Bring the nuts up tight with a wrench or nut driver.

The tuner can now be installed in the cabinet. The tuner is secured to the cabinet shelf by the insertion of the four 10/32 x 3/4 inch thumb screws supplied in the parts bag through the 1/4 inch holes, in the shelf.

**IMPORTANT: MAKE SURE THAT THE INNER CHASSIS FLOATS ON THE RUBBER SHOCK MOUNTING FEET, AND DOES NOT CONTACT THE CABINET OR TUNER PANEL.**

Next replace the felt washers and knobs.

Adequate ventilation is essential to the stable operation of any tuner. Do not put a solid back on the cabinet behind the tuner. If the tuner is mounted vertically make sure sufficient ventilation is supplied.

Installation in the L-55 cabinet is done by the same procedure as for installation in a custom cabinet. The cabinets are supplied with the cutouts and holes all prepared.

### CONNECTING PROCEDURE

**FM ANTENNA:** In high signal strength areas a minimum antenna, such as the folded dipole supplied, is all that is needed for local reception. Some care should be used in locating the folded dipole in a position that is free as possible from local noise sources and shielding such as metal roofing and building framework. The dipole should be mounted horizontally, and at 90° to the line of sight path to the transmitting stations.

In fringe areas a good antenna is required. A highly directional broad band antenna used in conjunction with a rotor will result in superior performance in low signal strength areas.

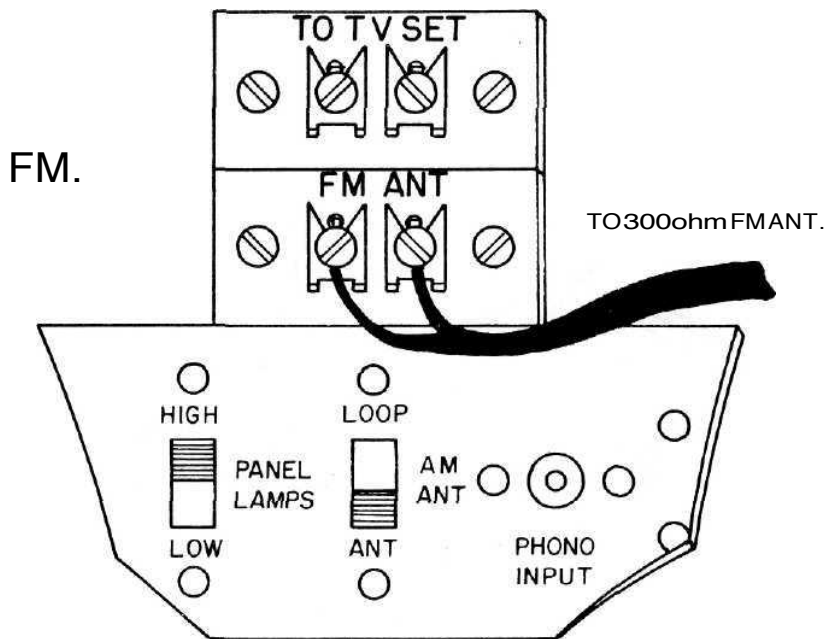

A substitute for the folded dipole can be an existing VHF T. V. antenna. The MR-55 is supplied with an internal switching arrangement that eliminates the need for two set couplers. The VHF T. V. antenna lead-in is connected to the antenna terminals marked "FM. ANT." Connect the terminals marked "TO T. V. SET" to the antenna terminals on the T. V. receiver with 300 ohm antenna lead. When the MR-55 selector switch is in either of the "FM" positions the antenna is disconnected automatically from the T. V. receiver. In any other position of the selector switch the antenna is connected to the T. V. set and disconnected from the tuner.

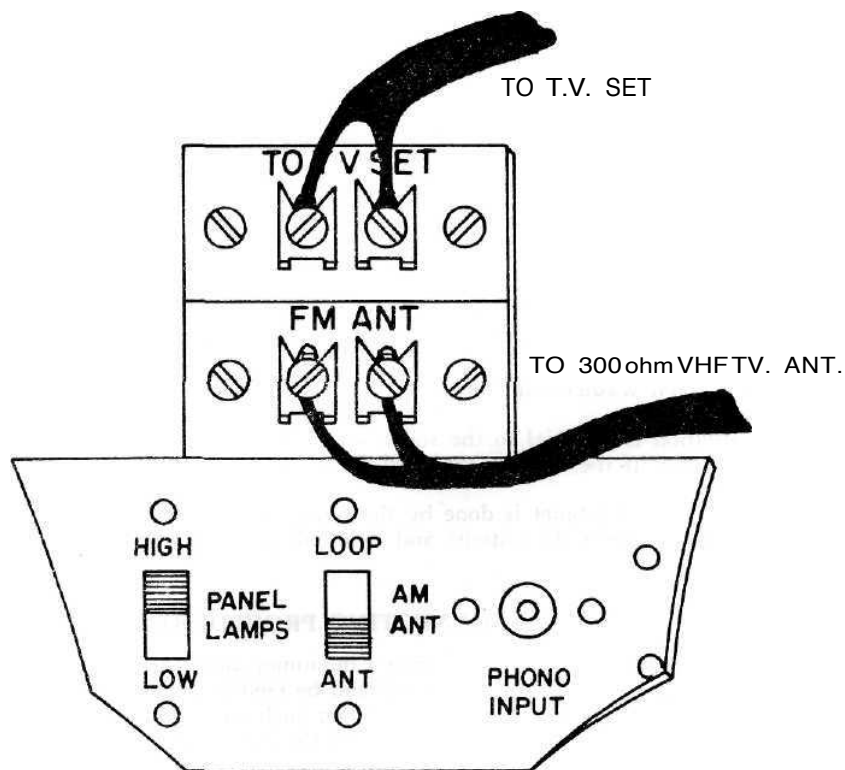

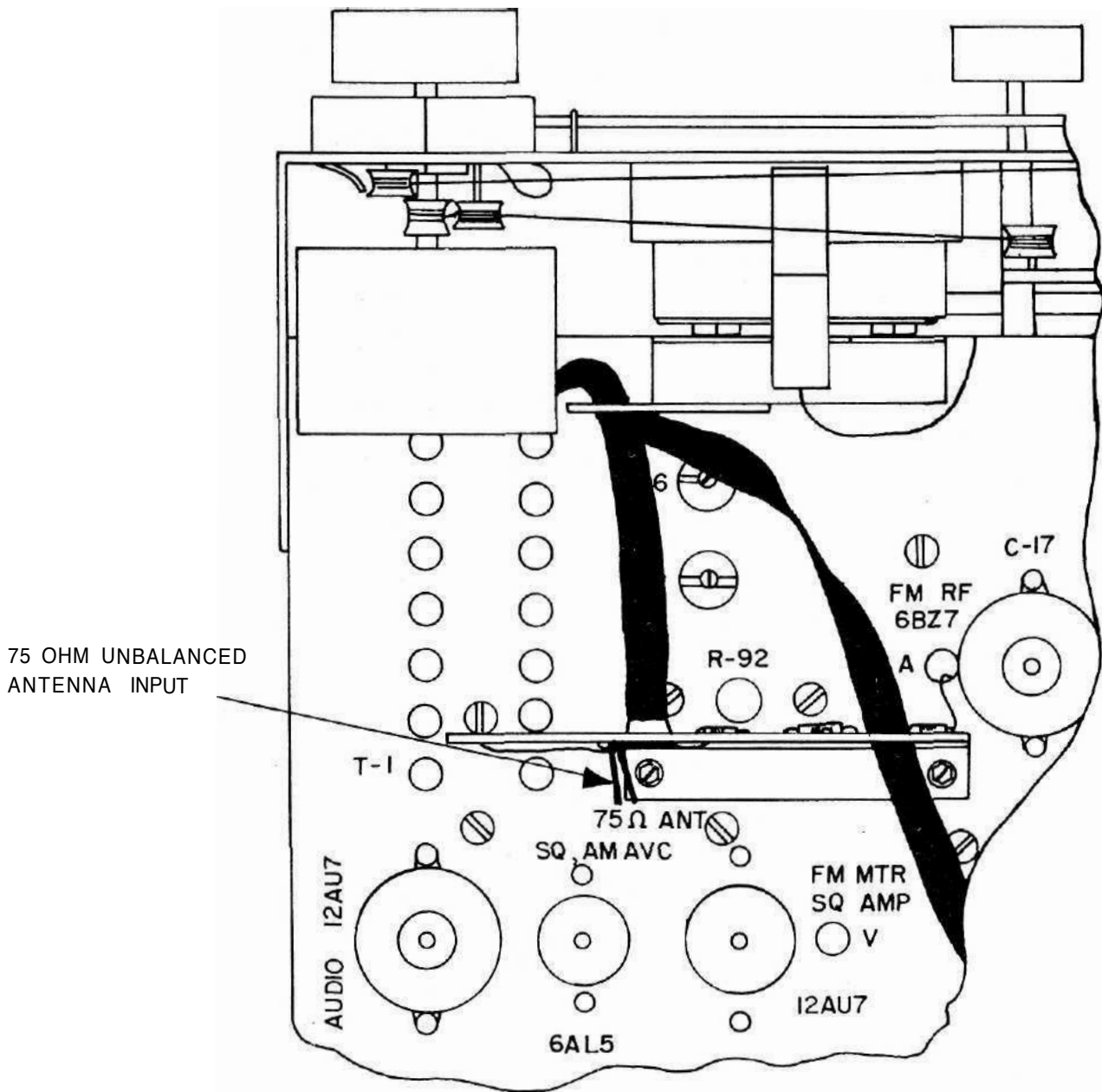

75 OHM UNBALANCED  
ANTENNA INPUT

**75 OHM ANTENNA:** The MR-55 has provision for the connection of a 75 ohm unbalanced antenna. The 75 ohm terminal screws are next to the chassis on the back of the brown bakelite balun card located approximately 2 inches behind the tuning knob flywheel. The center conductor of the 75 ohm coaxial lead is attached to the screw terminal located 3/8 inch above the chassis. The outer conductor or ground side is connected to the screw terminal located close to the chassis. Solderless spade lugs are supplied for your convenience.

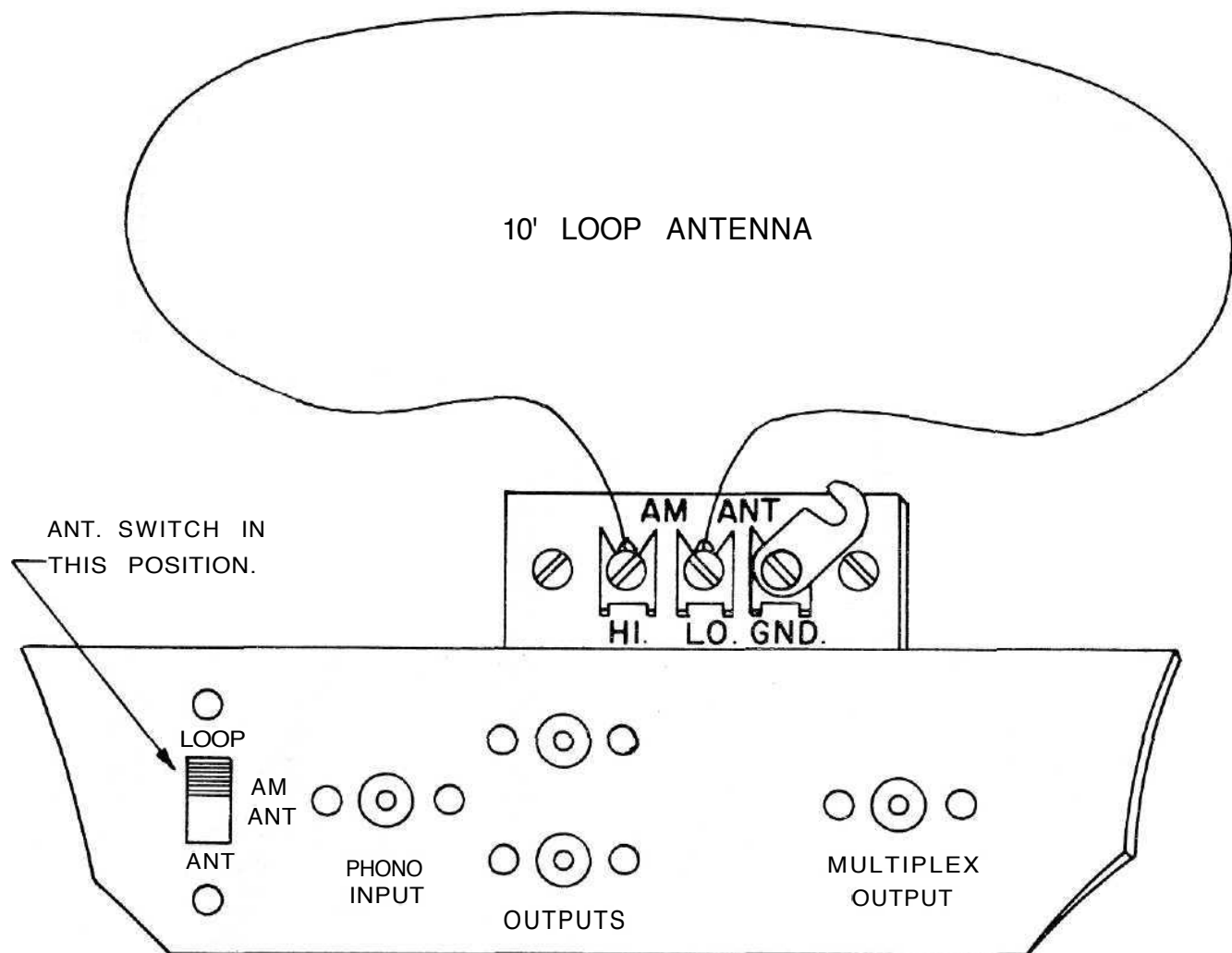

A. M. ANTENNA: Facilities are supplied on the MR-55 for the use of a low impedance loop antenna or a high impedance long wire antenna. AM reception will generally be improved through the use of a properly installed long wire outside antenna.

For locations where an outside antenna is impossible or impractical a 10 foot loop antenna is supplied. The loop is attached between the terminals marked "HI" and "LO" on the "AM. ANT" terminal strip. The "AM. ANT" terminating switch, located left of center next to the phono input jack on the back panel of the tuner, must be in the loop position.

Orientation of the loop is critical. It should be mounted in as large a circle as practical in the vertical plane.



An outside AM antenna is a wire as long as practical, mounted as high as possible above the ground, at right angles to power lines. The lead should be carefully positioned away from all A. C. lines,

The "ANTENNA" terminating switch must be in "ANT" position when using outside or long wire antenna.

A good ground can be of assistance in AM reception. A good ground is described as a 1/2 inch rod 6 to 8 feet long driven into the earth. The ground wire is connected to the terminal marked "LO."

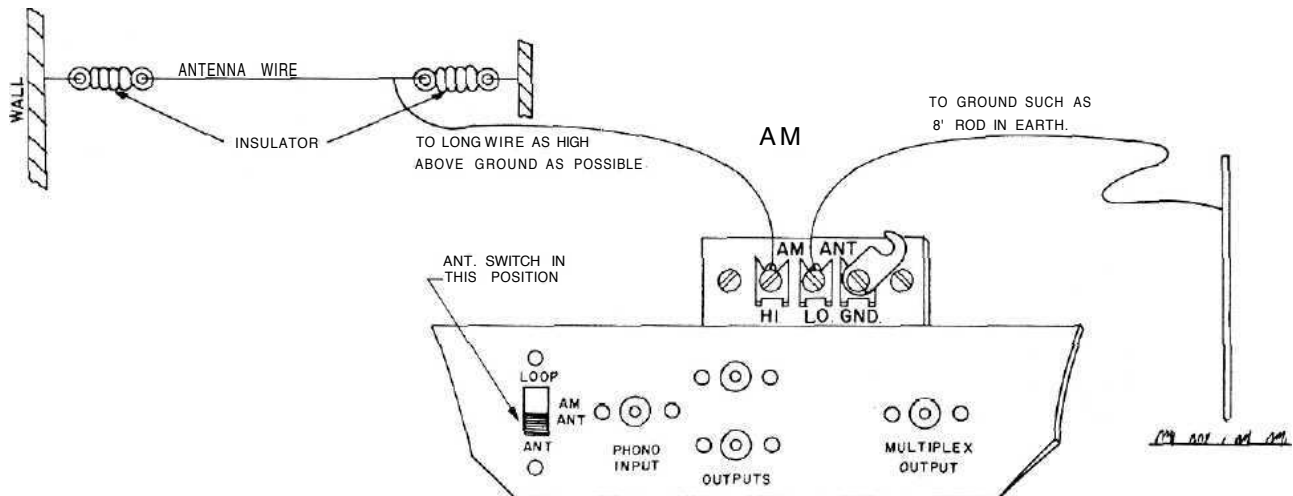

If the tuner is connected to an outside ground as described above do not connect any of the other equipment to the same ground to prevent ground loops. Ground loops can cause an increase in hum.

For an alternate ground for use when using a long wire antenna connect the shorting link between terminals marked "LO" and "GND."

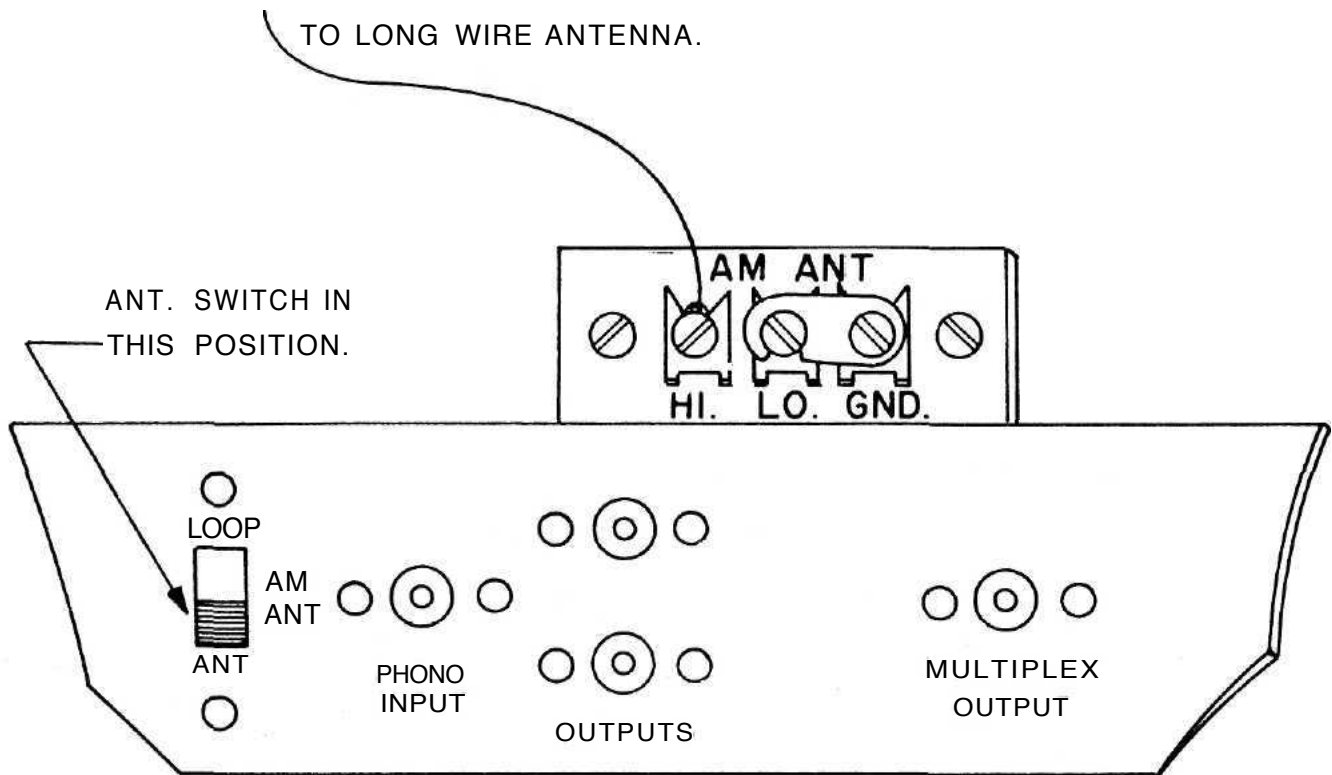

OUTPUT: Two pin jacks are supplied on the back panel marked "Output." These jacks are in parallel. The output is unbalanced low impedance. Interconnect between either of these jacks and the tuner input of your preamplifier by means of the 6 foot shielded cable supplied with your tuner.

Plug the A. C. cable from the tuner into one of the auxiliary A. C. outlets on the back of the preamplifier.

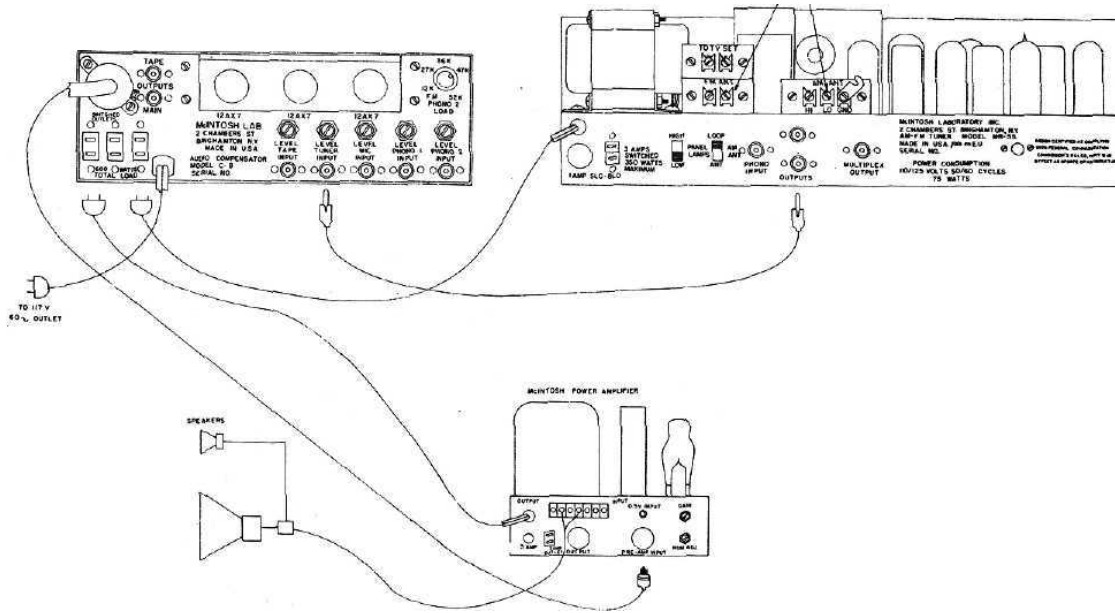

The A. C. cable from the amplifier can be plugged into the auxiliary A. C. outlet supplied on the back of the MR-55. This outlet is controlled by the A. C. switch on the front of the tuner.

SEE ANTENNA INSTALLATION INSTRUCTIONS

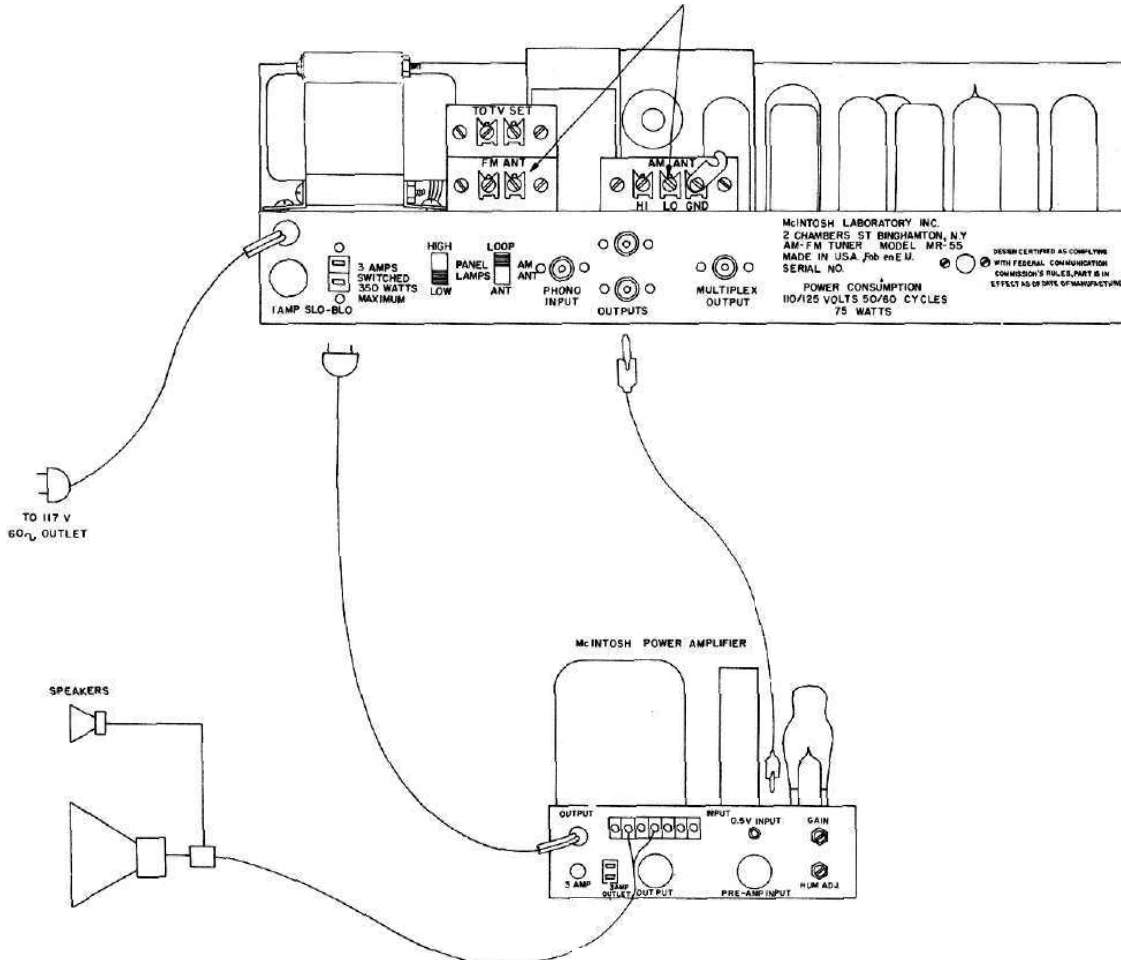

## **Multiplex Output**

The output on the back of the MR-55 marked "MULTIPLEX OUTPUT" is an unfiltered output for feeding a multiplex adapter.

## **OPERATION**

The selector switch is a six position switch that has the following identifications: (1) F. M. LISTEN, (2) F. M. TUNE, (3) A. M. BRD. (4) A. M. MED., (5) A. M. SHARP, (6) PHONO.

### **Phono**

The input sensitivity is 0.25 volts, suitable for a crystal or ceramic type phono cartridge, a magnetic cartridge with a one tube preamplifier, or the output of a tape recorder.

### **A. M. Sharp**

The audio response of this position is limited to 20 cycles to 2000 cycles. In the "A. M. SHARP" position distant stations can be received with maximum clarity and minimum noise. Tune to a peak on the signal strength or right meter. The left meter or center of channel meter is only in use on F. M.

### **A. M. Med.**

The audio response of the A. M. MED. position is limited to 20 cycles to 6500 cycles. This position is less selective on noise than the "SHARP" position.

### **A. M. Brd.**

The unrestricted audio response is 20 to 10,000 cycles for maximum A. M. fidelity on strong local stations where noise is not a problem. Tune to a dip between two peaks on the signal strength meter, or the loudest sound.

### **Whistle Filter**

In all A. M. positions there is a 70 DB rejection of the 10 K.C whistle.

### **F. M. Tune**

Automatic frequency control (A. F. C.) is disabled and ULTRASONIC MUTING is added for maximum accuracy and ease in tuning. Ultrasonic muting eliminates the annoying noise between stations. In tuning across the band take notice of the complete absence of noise even when approaching a station.

Some stations are received with insufficient signal strength to completely eliminate background "noise. The ultrasonic muting circuit has been so designed to permit only listenable signals through. Signals with annoying background noise will be muted. The meters will function normally and indicate the presence of a station. If a desired station is not heard, tune by meter and change the selector switch to "F. M. LISTEN." The station can then be heard. Ultrasonic muting is an exclusive McIntosh development and feature.

If an antenna with a rotor is used the signal strength meter can be of assistance in determining the proper direction to point the antenna. Rotate the antenna until maximum signal strength is registered on the meter. The best signal to noise ratio usually will result at highest indicated signal strength.

### **F. M. Listen**

The ultrasonic muting circuit is defeated and A. F. C. added for greatest listening pleasure. McIntosh A. F. C. does not change in any respect the low distortion characteristics of the MR-55.

### **Volume**

The volume control has at its extreme counter-clockwise rotation the A. C. on-off switch. The switch also controls the A. C. available at the auxiliary A. C. outlet on the back of the tuner. Normal operation for the "VOLUME" control is totally clockwise.

### **A. M. Sensitivity**

The A. M. sensitivity is the greatest at the clockwise position of the switch, the center position is intermediate sensitivity, and the counter-clockwise position is minimum sensitivity.

The clockwise or maximum sensitivity position will deliver the greatest number of stations. Long distant reception will be best in this position. When selecting local stations between station noise can be reduced by using either the minimum or intermediate sensitivity positions which ever is most satisfactory for your location.

## **A. F. C.**

The A. F. C. is completely variable from off at the counter-clockwise position of the control to full on at the extreme clockwise end of its rotation. In areas where weak stations are near strong stations on the dial only enough A. F. C. need be used to hold the weak station. No change in audio quality will be detected over the complete rotation of the A. F. C. control.

## **Dial**

In addition to the regular A. M. and F. M. identification on the dial a logging scale has been supplied to facilitate repeat tuning of familiar stations.

## **SERVICE INFORMATION**

All McIntosh equipment is designed for long trouble free operation. All components are of highest quality and are conservatively operated. If trouble develops the equipment may be serviced by your franchised dealer, a competent serviceman, or returned to the factory. Equipment will not be accepted at the factory unless factory return authorization is first received.

Complete step by step alignment procedures are outlined in this manual. The MR-55 is a professional device dependent for its superior performance on critical and proper adjustment. Adjustments should be made only by thoroughly qualified personnel, and with the proper equipment. The minimum recommended equipments are as follows:

1. Low distortion FM-AM Sweep generator, such as Boonton 202E.
2. Low distortion AM Signal generator such as Measurements 65B.
3. Univerter such as Boonton 207E.
4. Distortion analyzer such as Hewlett Packard 330B.
5. Oscilloscope such as Dumont 274A.
6. Vacuum tube Voltmeter such as R. C. A. WV-98A.

Much research has been done in our laboratory to overcome the need for alignment and adjustment encountered in high quality tuners. Design parameters have been selected so that major changes can occur in components without degrading the high quality results. Tube replacements seldom require re-alignment. Transformers have been made mechanically captive to prevent misalignment due to vibration and shock. Therefore, the need for adjustment and alignment has been substantially reduced. McIntosh Laboratory, of course, will align and adjust any tuner upon request.

## **GUARANTEE**

We guarantee the performance of this equipment and the mechanical and electrical workmanship to be free of serious defects for a period of 90 days. This guarantee does not extend to components damaged by improper use nor does it extend to transportation to and from the factory.

**McINTOSH LABORATORY, INC.**  
**2 Chambers Street**  
**Binghamton, N. Y., U.S.A.**

In Canada: Manufactured Under License by McCurdy Radio Industries, Ltd.  
22 Front Street West, Toronto, Canada