

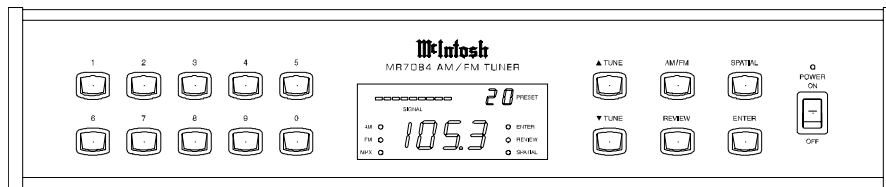

AM / FM Tuner



MR7084



Thank You, Please Take A Moment, Customer Service and Table of Contents

Thank You

For your decision to own this McIntosh MR7084 AM / FM Tuner ranks you at the very top among discriminating music listeners. You now have "The Best." The McIntosh dedication to "Quality," is assurance that you will receive many years of musical enjoyment from this unit.

Please take a short time to read the information in this manual. We want you to be as familiar as possible with all the features and functions of your new McIntosh MR7084. This will ensure that you receive all the performance benefits this equipment can offer you, and that it will become a highly valued part of your home entertainment system.

Please Take A Moment

The serial number, purchase date and McIntosh dealer name are important to you for possible insurance claim or future service. The serial number is located on the rear panel of the equipment. The spaces below have been provided for you to record that information:

Serial Number:

Purchase Date:

Dealer Name:

Customer Service

If at any time you have questions about your MR7084 AM / FM Tuner, please contact:

McIntosh Laboratory, Inc.
2 Chambers Street
Binghamton, New York 13903
Phone: 607-723-3512
FAX: 607-724-0549

Table of Contents

Thank You	2
Please Take a Moment	2
Customer Service	2
Table of Contents	2
Safety Instructions	3
Introduction	5
Performance Features	5
Installation	6
Rear Panel Connections	7
How to Connect	8
Front Panel Controls, Displays, Push-Buttons, and Switches	9
How to Operate	10
Preset Reference Table	12
Specifications	14
Packing Instruction	15

NOTES:

- Four different types of FM antennas can be used with the MR7084*
 - The flexible indoor dipole antenna supplied with your MR7084 makes a convenient antenna for urban or high signal strength areas. Extend the two dipole sections as straight as possible. The antenna can be placed behind a cabinet, under a rug or along the wall. Since the antenna is directional, you may have to experiment with the position for best reception. An indoor antenna may not prove effective in houses or buildings with metal siding or insulation.*
 - An existing VHF-TV antenna can be connected. Consult McIntosh Dealers for assistance.*
 - An outdoor directional FM antenna with a rotor is the best for optimum reception in all areas. A rotor allows you to position the antenna for the best possible reception of a specific FM station.*
 - A signal from your local cable company can also be connected. Consult your cable company for installation assistance.*
 - All connection hook ups to the MR7084 require either RG6 or RG59U coaxial cable.*
- When the MR7084 is packed for shipping, the AM loopstick antenna is folded flat and taped against the rear panel. Remove the securing tape and fold it out, away from the panel for proper AM reception. The AM loopstick antenna is directional so it is designed to be easily moved to a wide range of positions, as this will effect reception of your favorite AM stations.*

IMPORTANT SAFETY INSTRUCTIONS!

PLEASE READ THEM BEFORE OPERATING THIS EQUIPMENT.



WARNING SHOCK HAZARD - DO NOT OPEN.



AVIS RISQUE DE CHOC - NE PAS OUVRIR.

CAUTION
RISK OF ELECTRIC SHOCK
DO NOT OPEN

ATTENTION
DANGER D'ELECTROCUTION
NE PAS OUVRIR

NO USER-SERVICEABLE PARTS INSIDE. REFER SERVICING TO QUALIFIED PERSONNEL

General:

1. Read all the safety and operating instructions, contained in this owner's manual, before operating this equipment.
2. Retain this owner's manual for future reference about safety and operating instructions.
3. Adhere to all warnings and operating instructions.
4. Follow all operating and use instructions.
5. **Warning: To reduce risk of fire or electrical shock, do not expose this equipment to rain or moisture. This unit is capable of producing high sound pressure levels. Continued exposure to high sound pressure levels can cause permanent hearing impairment or loss. User caution is advised and ear protection is recommended when playing at high volumes.**
6. **Caution: to prevent electrical shock do not use this (polarized) plug with an extension cord, receptacle or other outlet unless the blades can be fully inserted to prevent blade exposure.**
Attention: pour prevenir les chocs electriques pas utiliser cette fiche polarisee avec un prolongateur, une prise de courant ou un autre sortie de courant, sauf si les lames peuvent etre inserees afond ans en laisser aucune partie a decouvert.
7. For added protection for this product during a lightning storm, or when it is left unattended and unused for long periods of time, unplug it from the wall outlet and disconnect the antenna or cable system. This will prevent damage to the product due to lightning or power line surges.

8. Do not use attachments not recommended in this owner's manual as they may cause hazards.

Installation:

9. Locate the equipment for proper ventilation. For example, the equipment should not be placed on a bed, sofa, rug, or similar surface that may block ventilation openings; or, placed in a built-in installation, such as a bookcase or cabinet, that may impede the flow of air through the ventilation openings.
10. Locate the equipment away from heat sources such as radiators, heat registers, stoves, or other appliance (including amplifiers) that produce heat.
11. Mount the equipment in a wall or cabinet only as described in this owner's manual
12. Do not use this equipment near water; for example, near a bathtub, washbowl, kitchen sink, laundry tub, in a wet basement or near a swimming pool, etc.
13. Do not place this product on an unstable cart, stand, tripod, bracket, or table. The equipment may fall, causing serious injury to a person, and serious damage to the product.

Connection:

14. Connect this equipment only to the type of AC power source as marked on the unit.
15. Route AC power cords so that they are not likely to be walked on or pinched by items placed upon or against them, paying particular attention to cords at plugs, convenience receptacles, and the point where they exit from the instrument.
16. Do not defeat the inherent design features of the polarized plug. Non-polarized line cord adapters will defeat the safety provided by the polarized AC plug. If the plug should fail to fit, contact your electrician to replace your obsolete outlet. Do not defeat the safety purpose of the grounding-type plug.
17. Do not overload wall outlets, extension cords or integral convenience receptacles as this can result in a risk of fire or electric shock.

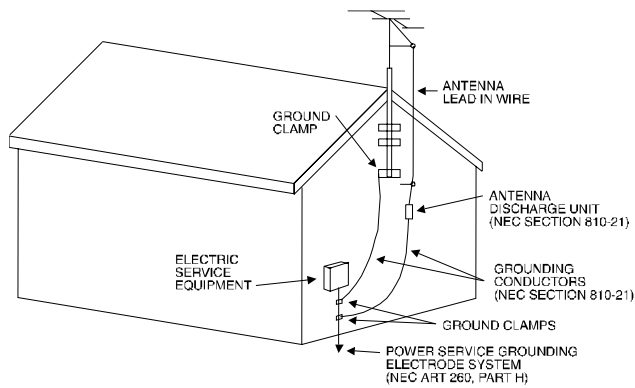

Outdoor Antenna:

18. If an outdoor antenna is connected to the antenna system is grounded to provide some protection against voltage surges and built up static charge. In the U.S.A., section 810 of the National Electrical Code, ANSI/NFPA No. 70-1978, provides information on the proper ground for the mast and supporting structure, ground for the lead-in wire to an antenna discharge unit, and size of ground conductors, location of antenna-discharge unit, connection to ground electrode. For ground wire:
 - A. Use No. 10 AWG (5.3 mm²) copper No. 8 AWG (8.4 mm²) aluminum, No. 17 AWG (1.0 mm²) copper-clad steel, bronze, or larger as ground wire.
 - B. Secure antenna lead-in and ground wires to the house with stand-off insulators spaced from 4 feet (1.2 meters) to 6 feet (1.83) meters apart.
 - C. Mount antenna discharge unit as closely as possible to where lead-in enters house.
 - D. Use jumper wire not smaller than No. 6 AWG (13.3 mm²) copper or equivalent when separate antenna grounding electrode is used.

Care of Equipment:

19. Clean the instrument by dusting with a dry cloth. Unplug this equipment from the wall outlet and clean the panel with a cloth moistened with a window cleaner. Do not use liquid cleaners or aerosol cleaners.
20. Do not permit objects of any kind to be pushed and/or fall into the equipment through enclosure openings. Never spill liquids into the equipment through enclosure openings.
21. Unplug the power cord from the AC power outlet when left unused for a long period of time.

Repair of Equipment:

22. Unplug this equipment from the wall outlet and refer servicing to a qualified service personnel under the following conditions:
 - A. The AC power cord or the plug has been damaged,
 - B. Objects have fallen, or liquid has been spilled into the equipment,
 - C. The equipment has been exposed to rain or water,
 - D. The equipment does not operate normally by following the operating instructions contained within this owner's manual. Adjust only those controls that are covered by the operating instructions, as an improper adjustment of other controls may result in damage and will often require extensive work by a qualified technician to restore the product to its normal operation,
 - E. The equipment has been dropped or damaged in any way,
 - F. The equipment exhibits a distinct change in performance - this indicates a need for service.
23. Do not attempt to service beyond that described in the operating instructions. All other service should be referred to qualified service personnel.
24. When replacement parts are required, be sure the service technician has used replacement parts specified by McIntosh or have the same characteristics as the original part. Unauthorized substitutions may result in fire, electric shock, or other hazards.
25. Upon completion of any service or repairs to this product, ask the service technician to perform safety checks to determine that the product is in proper operating condition.

Introduction and Performance Features

Introduction

The McIntosh MR7084 AM/FM Tuner will reproduce all the quality performance that any AM or FM station can broadcast. It also provides a wide range of performance features that make your radio listening easier and more enjoyable.

Performance Features

- **Preset Stations**

50 station memory presets are available in any combination of AM and FM stations.

- **Preset Clear Push-button**

Rear panel Preset Clear push-button instantly clears the stored memory of all 50 presets to allow reassigning.

- **Preset Memory**

Preset memory is retained even when AC power is turned off.

- **Numeric Keypad**

10 push-button front panel array allows instant preset access.

- **Remote Controllable**

Full remote control operation is possible when the MR7084 is used with a contemporary McIntosh remote controlled Preamp or Control Center.

- **AM Enhancement**

The built-in McIntosh SPATIAL circuit modifies frequency and phase response for a stereo effect on mono AM stations.

- **Auto Mute**

Muting is automatically activated when changing stations.

- **Electronic memory mode**

Electronic memory mode causes tuner to return to last selected mode of operation when power switch is turned on.

- **Memory Review**

Memory review allows you to audition each preset automatically for five seconds.

- **Versatile Outputs**

Both fixed and variable audio outputs included.

- **Display Provisions**

Scope outputs allow an oscilloscope to be connected for viewing FM Multipath, station signal strength and center tuning accuracy.

- **Special RF Amplifier**

Double-Diffused Metal Oxide Field Effect Transistor (DMOS-FET) RF amplifier increases sensitivity and Cross Modulation rejection.

- **Remote AM Antenna Hookup**

Rear panel DIN connector provided to allow the addition of a McIntosh RAA1 Remote AM Antenna for improved AM reception with reduced noise and interference.



Installation

The MR7084 can be placed upright on a table or shelf, standing on its four feet. It also can be custom installed in a piece of furniture or cabinet of your choice. The required panel cutout, ventilation cutout and unit dimensions are shown.

Always provide adequate ventilation for your MR7084. Cool operation ensures the longest possible operating life for any electronic instrument. Do not install the MR7084 directly above a heat generating component such as a high powered amplifier. If all the components are installed in a single cabinet, a quiet running ventilation fan can be a defini-

nite asset in maintaining all the system components at the coolest possible operating temperature.

A custom cabinet installation should provide the following minimum spacing dimensions for cool operation. Allow at least 1-1/2 inches (3.8cm) above the unit so airflow is not obstructed. Allow 17-1/2 inches (44.5cm) depth behind the mounting panel, which includes clearance for connectors. Allow 1-1/8 inches (2.9cm) in front of the mounting panel for knob clearance. Be sure to cut out a ventilation hole in the mounting shelf according to the dimensions in the drawing.

Front View of the MR7084 custom installed

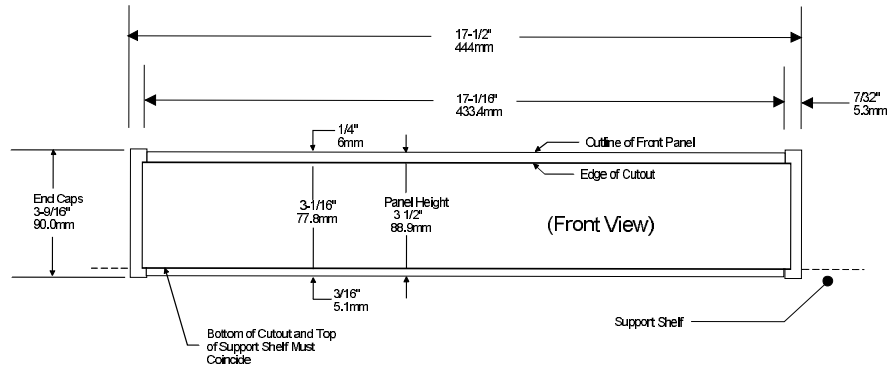

Side View of the MR7084 custom installed

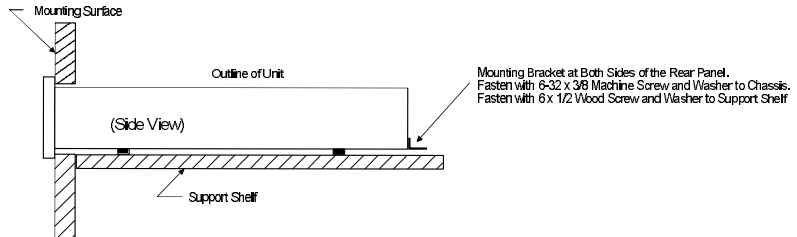

Bottom View of the MR7084 custom installed

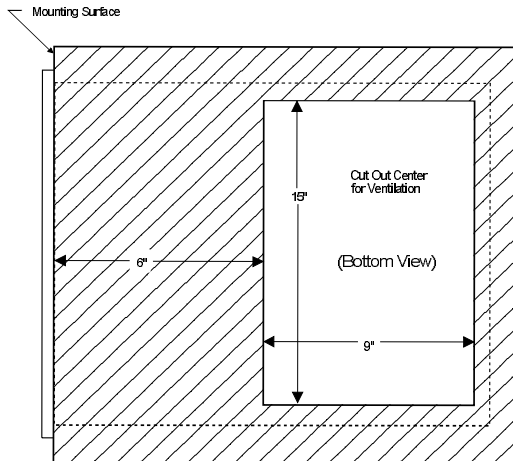

MR7084 Rear Panel Connections

MR7084 Rear Panel Connections

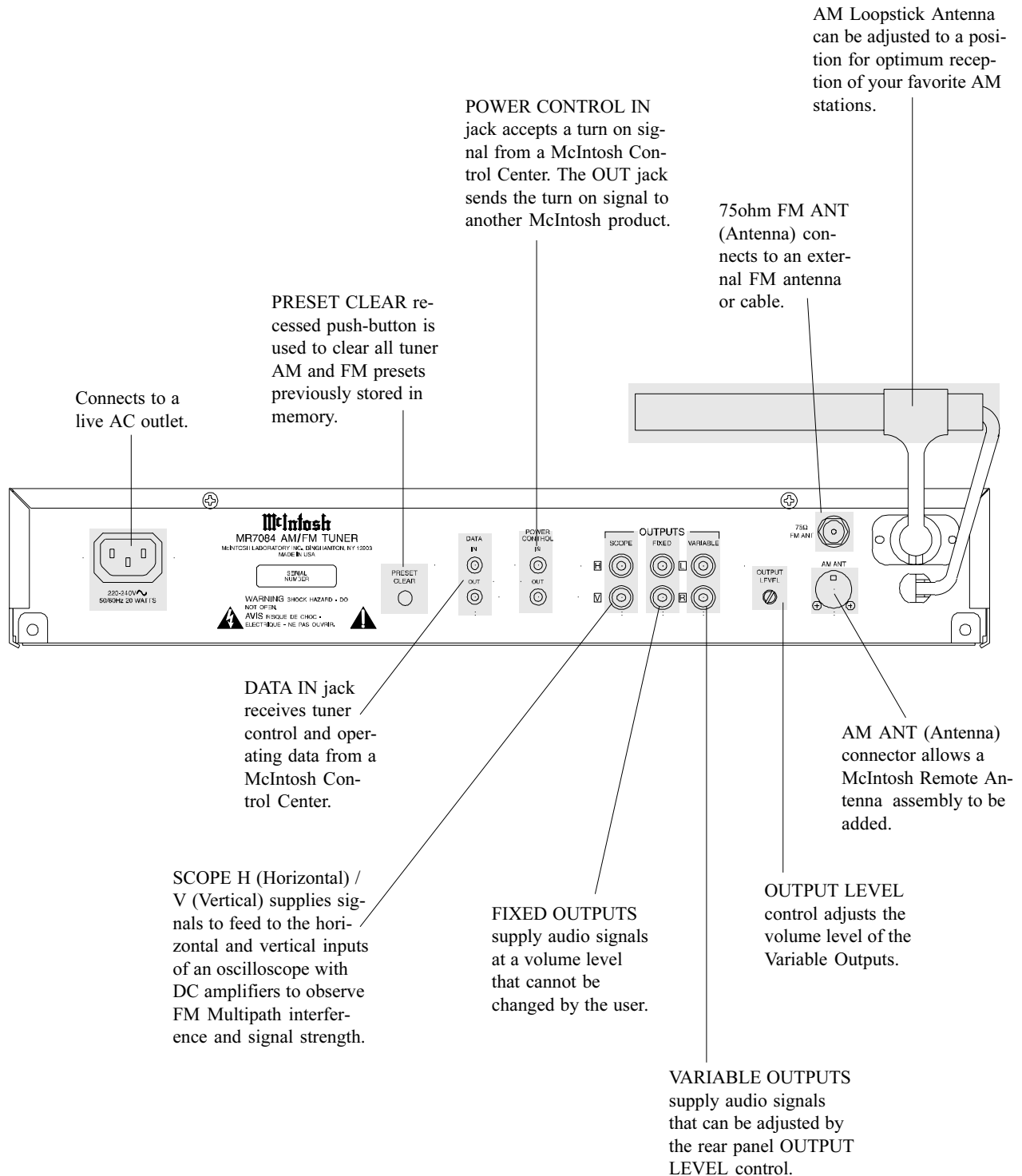



How to Connect the MR7084

How to Connect the MR7084

1. Connect a Data cable from the DATA IN jack to the TUNER DATA PORT of a McIntosh Control Center or preamplifier.

NOTE: A Data cable consists of a mono or stereo shielded cable with 1/8 inch mini phone plugs on each end. Connections are to the tip (+) and sleeve (-) of the plugs. (McIntosh Part No. 170-202)

2. Connect a Data cable from the POWER CONTROL IN jack to the POWER CONTROL OUT jack of a McIntosh Preamplifier, Control Center or other McIntosh component.
3. Connect shielded cables from the SCOPE OUTPUTS to the Horizontal and Vertical Inputs of an oscilloscope with DC amplifiers.

4. Connect shielded cables from the FIXED OUTPUTS to the Tuner inputs of a preamplifier or control center.
5. Connect shielded cables from the VARIABLE OUTPUTS to the Tuner inputs of a preamplifier or control center.
6. Connect the flexible FM antenna supplied with the tuner, an external FM antenna or cable to the FM ANT connector.
7. Connect the DIN plug of a McIntosh Remote AM Antenna assembly to the AM ANT socket.

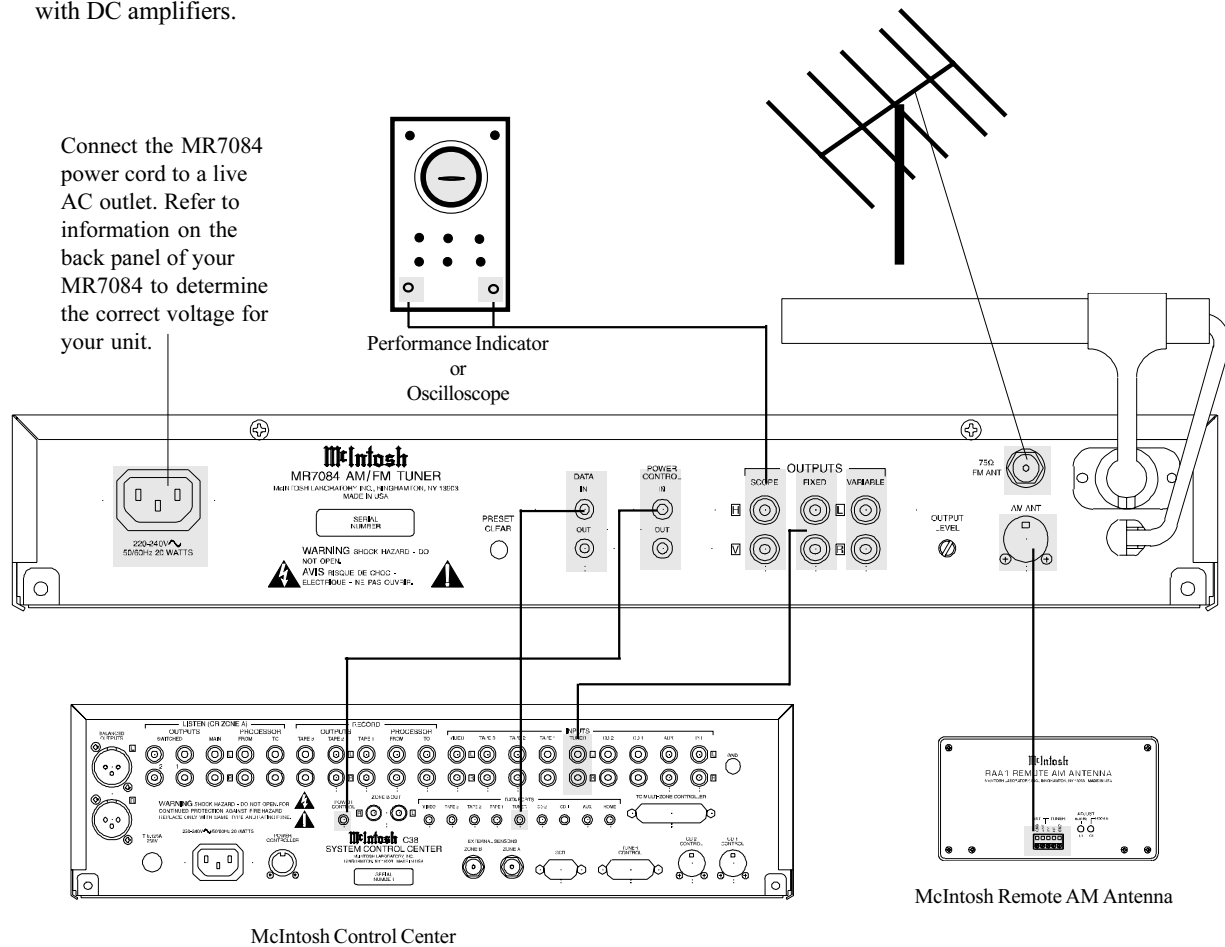

MR7084 Front Panel Display, Push-Buttons and Switches

MR7084 Front Panel Display, Push-Buttons and Switches

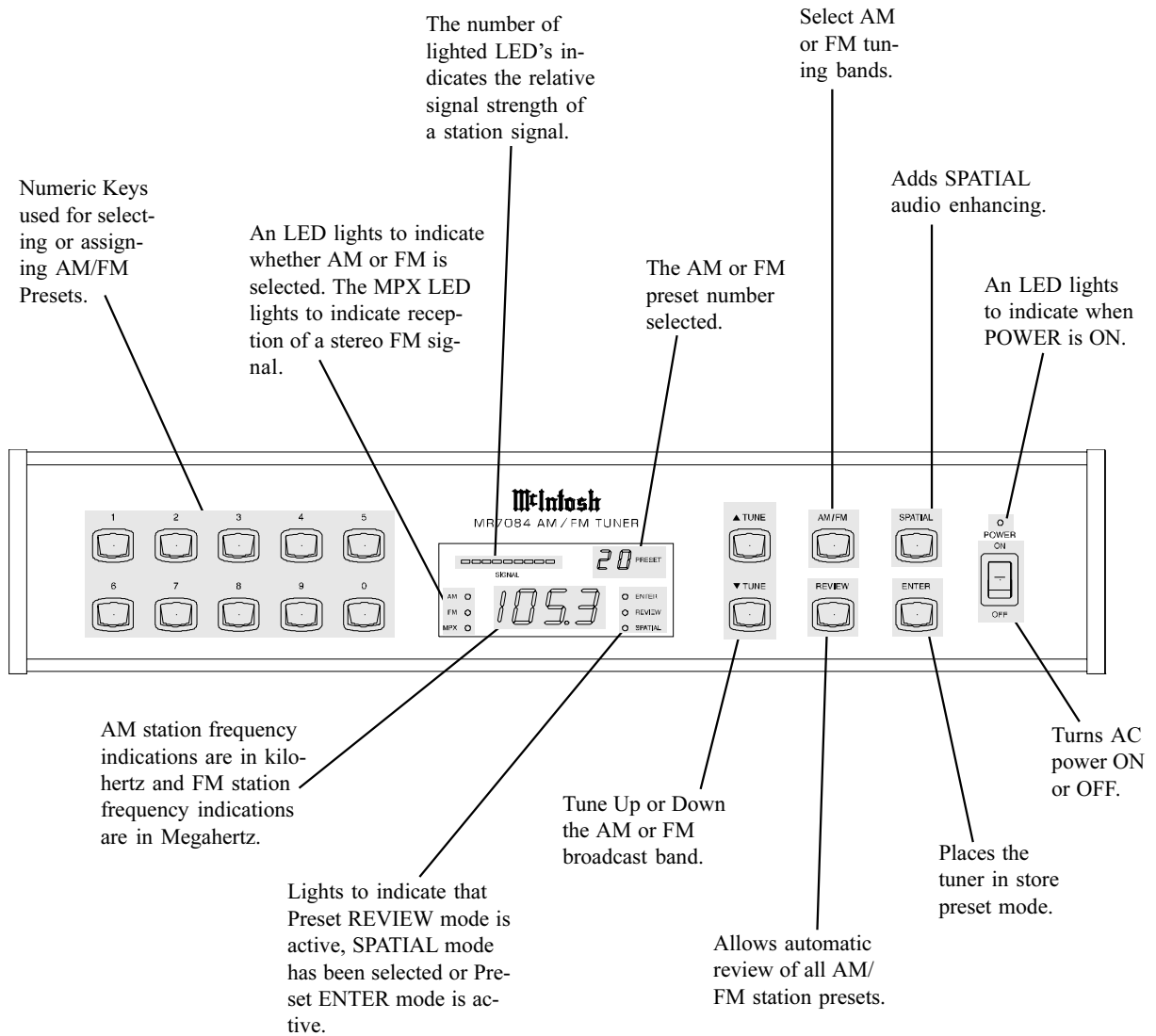



How to Operate the MR7084

How to Operate the MR7084

The MR7084 can be turned on manually with the front panel Power switch. When the Power Control cable is connected to a McIntosh Control Center or Preamplifier, the MR7084 Power switch can be left on, and the tuner will turn on whenever the other component turns on. Refer to figures 1 and 2.

NOTE: All US and Canadian FM station broadcast frequencies end in an ODD number after the decimal point on the display. In Europe, the display indicates 50KHz steps by adding a second decimal point after the 100KHz display digit. For example, a station at 107.3 would indicate directly. If the display read 107.3., it would indicate a station 50KHz higher, or 107.35. In Europe and Japan the AM display changes in 9KHz steps.

Select the AM or FM broadcast band by pressing the appropriate push-button.

Press the UP or DOWN TUNE push-button to select stations on either the AM or FM broadcast band. AM band indications are in kilohertz and change frequency in 10kHz steps. FM band indications are in Megahertz and change frequency in 100kHz steps.

You can also tune to AM or FM stations by using the assigned preset push-buttons. When selecting preset numbers from 1 through 9, first press "0" and then the single digit preset push-button. When selecting preset numbers from 10 through 50, press the desired two push-buttons in sequence.

Tune to a station preset by pressing the REVIEW push-button. This starts the automatic 5 second audition of each of the preset stations stored in the PRESET memory. The REVIEW LED lights when this process is active. Only the presets stored in memory will be reviewed. If only five presets have been stored in memory, only those five will be reviewed. Press REVIEW a second time to stop on the desired preset station, and exit the REVIEW process. The REVIEW LED

then turns off. The REVIEW process can also be canceled by pressing any other tuner function push-button. The number of LED's that light on the front panel SIGNAL display indicates the relative strength of a station signal being received. The AM loopstick is moveable and often can be positioned to increase the signal strength of your favorite AM station. If your FM antenna is moveable, adjust it for the optimum reception of your favorite FM station, indicated by the maximum number of non-flickering LED's.

Press the Spatial push-button to add audio enhancing to either an AM or FM signal. For example, mono AM signals will have a simulated stereo effect.

How To assign FM Station Presets

1. Select the FM broadcast band. Refer to figure 1.
2. Tune to the desired FM station frequency using the TUNE push buttons.
3. Momentarily press and release the ENTER push button. The ENTER LED will light.

NOTE: Be sure to just momentarily press and then release the ENTER push-button. If the ENTER push-button is held in, the ENTER LED will turn back off and the assigning mode will be canceled. The ENTER LED must be ON for preset assigning to occur. The MR7084 will remain in the preset ENTER mode for 10 seconds to allow the following preset assigning steps.

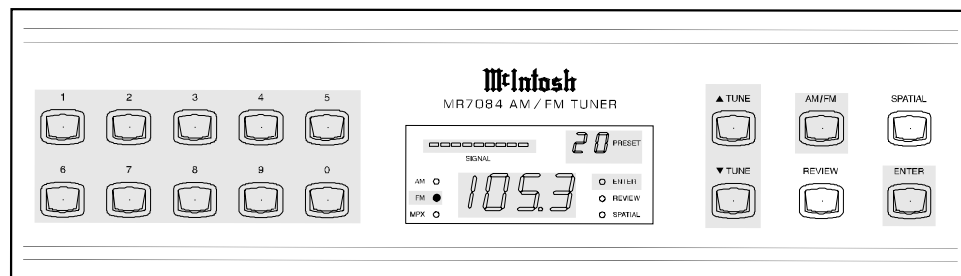

Figure 1

4. Push a PRESET push-button or sequence of push-buttons (from 0 through 50) to select a preset number that you wish to assign to a station. When selecting or assigning single preset numbers from 1 through 9, press "0" first, and then the single digit preset push-button.

How to Operate the MR7084, con't

- Press and release the ENTER push-button a second time to activate the assignment memory. The ENTER LED will turn off and the FM station selection preset will be assigned to the chosen preset number.

How To assign AM Station Presets

- Select the AM broadcast band. Refer to figure 2.
- Tune to the desired AM station frequency using the TUNE push buttons.
- Momentarily press and release the ENTER push button. The ENTER LED will light.

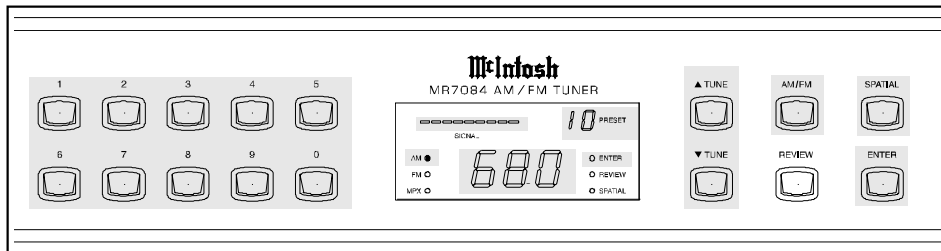

Figure 2

NOTE: Be sure to just momentarily press and then release the ENTER push-button. If the ENTER push-button is held in, the ENTER LED will turn back off and the assigning mode will be canceled. The ENTER LED must be ON for preset assigning to occur. The MR7084 will remain in the preset ENTER mode for 10 seconds to allow the following preset assigning steps.

- Push a PRESET push-button or sequence of push-buttons (from 0 through 50) to select a preset number that you wish to assign to a station. When selecting or assigning single preset numbers from 1 through 9, press "0" first, and then the single digit preset push-button.
- Press and release the ENTER push-button a second time to activate the assignment memory. The ENTER LED will turn off and the station selection preset will be assigned to the chosen preset number.

NOTE: Repeat steps 1 through 5 to assign presets for up to a total of 50, AM and FM station frequencies in any combination. Whenever a preset is selected, the tuner automatically switches to the appropriate AM or FM band according to the preset memory.

After all the desired station presets are assigned, press REVIEW to start the automatic 5 second audition of each of the preset stations stored in the PRESET memory. The REVIEW LED lights when this process is active. Only the presets stored in memory will be reviewed. If only five presets have been stored in memory, only those five will be reviewed. Press REVIEW a second time to stop on the desired preset station, and exit the REVIEW process. The REVIEW LED then turns off. The REVIEW process can also be canceled by pressing any other tuner function push-button.

How to Clear all station presets from memory

On the rear panel is a recessed PRESET CLEAR push-button (refer to figure 3) which allows you to clear all tuner AM and FM presets previously stored in memory. Use a device

such as a ball point pen or small screwdriver to press the PRESET CLEAR push-button. Press the push-button and hold it in for at least 5 seconds. The preset digits will start flashing on and off to indicate that the PRESET CLEAR function will occur. When the digits stop flashing, all the preset memories will then be instantly erased.

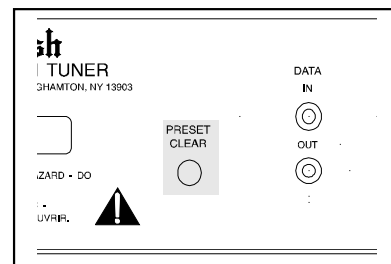

Figure 3

NOTE: If the MR7084 AC line cord is disconnected, or the AC power is interrupted, the tuner power supply turns off. However, the assigned Tuner presets will be retained until they are reassigned or cleared. If presets are not assigned, each preset number defaults to AM, 1710kHz.



Preset Reference Table

Preset No.	Frequency	Band	Call Letters	City	Remarks
1					
2					
3					
4					
5					
6					
7					
8					
9					
10					
11					
12					
13					
14					
15					
16					
17					
18					
19					
20					
21					
22					
23					
24					
25					

Preset Reference Table

Preset No.	Frequency	Band	Call Letters	City	Remarks
26					
27					
28					
29					
30					
31					
32					
33					
34					
35					
36					
37					
38					
39					
40					
41					
42					
43					
44					
45					
46					
47					
48					
49					
50					



Specifications

FM Section Specifications

Useable Sensitivity

15dB μ F which is 1.6 μ V across 75 ohms

50dB Quieting Sensitivity

Mono: 19dB μ F which is 2.5 μ V across 75 ohms

Stereo: 39dB μ F which is 25 μ V across 75 ohms

Signal To Noise Ratio

Mono: 80dB

Stereo: 75dB

Frequency Response

Mono: + 0, - 1dB from 20 to 15,000Hz

Stereo: + 0, - 1dB from 20 to 15,000Hz

Harmonic Distortion

Mono: 0.08% at 100Hz

0.08% at 1000Hz

0.12% at 10,000Hz

Stereo: 0.08% at 100Hz

0.08% at 1000Hz

0.12% at 10,000Hz

NOTE: Spectrum analyzer required for accurate measurement of Harmonic Distortion at 10,000Hz

Intermodulation Distortion

Mono, 0.08%

Stereo, 0.12%

Capture Ratio

1.5dB

Alternate Channel Selectivity

70dB

Spurious Response

100dB

Image Response

80dB

Stereo Separation

50dB

AM Section Specifications

Sensitivity

AM 20 μ V external antenna input (50 ohm source input)

Signal To Noise Ratio

50dB at 50% modulation

60dB at 100% modulation

Harmonic Distortion

0.5% maximum at 30% modulation

Frequency Response

50Hz to 6000Hz NRSC

NOTE: National Radio Systems Committee proposed spec. for AM tuners, Dec. 1989.

Adjacent Channel Selectivity

45dB minimum IHF

Image Rejection

78dB minimum

General Specifications

Audio Output

Fixed: 1.2V RMS at 100% modulation

Variable: 1.2mV to 1.2V at 100% modulation

Power Requirements

100 Volts, 50/60Hz at 20 watts.

110 Volts, 50/60Hz at 20 watts.

120 Volts, 50/60Hz at 20 watts.

220 Volts, 50/60Hz at 20 watts.

230 Volts, 50/60Hz at 20 watts.

240 Volts, 50/60Hz at 20 watts.

NOTE: Refer to the rear panel of the MR7084 for the correct voltage

Dimensions

17-1/2 inches (44.5cm) wide, 3-5/8 inches (9.2cm) high, 17-1/2 inches (44.5cm) deep, including clearance for connectors. Allow 3/4 inches (1.9cm) in front of the mounting panel for clearance.

Weight

15 pounds (6.8Kg) net, 27 pounds (12.2Kg) shipping

Packing Instructions

Packing Instructions

In the event it is necessary to repack the equipment for shipment, the equipment must be packed exactly as shown below. It is very important that the four plastic feet are attached to the bottom of the equipment. This will ensure the proper equipment location on the bottom pad. Failure to do this will result in shipping damage.

Use the original shipping carton and interior parts only if they are all in good serviceable condition. If a shipping carton or any of the interior part(s) are needed, please call or write Customer Service Department of McIntosh Laboratory. Please see the Part List for the correct part numbers.

Quantity	Part Number	Description
1	033770	Shipping carton only
2	033771	Cushion Pad
4	033772	Corner Pad
1	033606	Inside carton only
1	033726	Top pad
1	033729	Bottom pad
4	017218	Plastic foot
4	100159	#10-32 x 3/4" screw
4	104080	#10 Flat washer
1	048082	Shipping carton complete with all the above parts

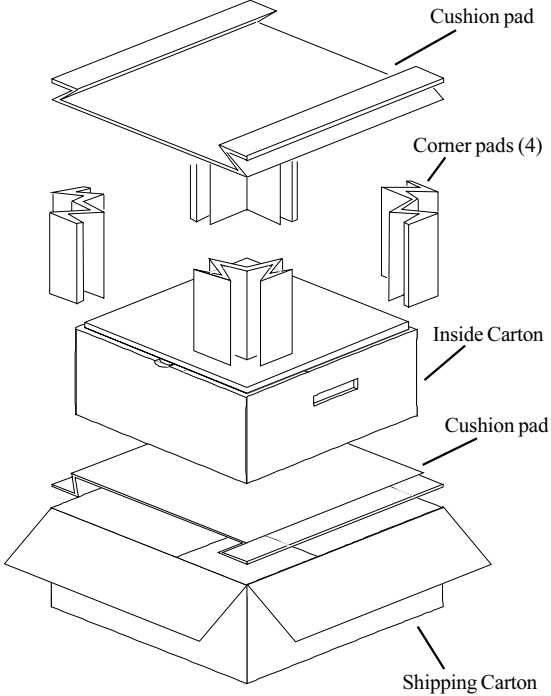
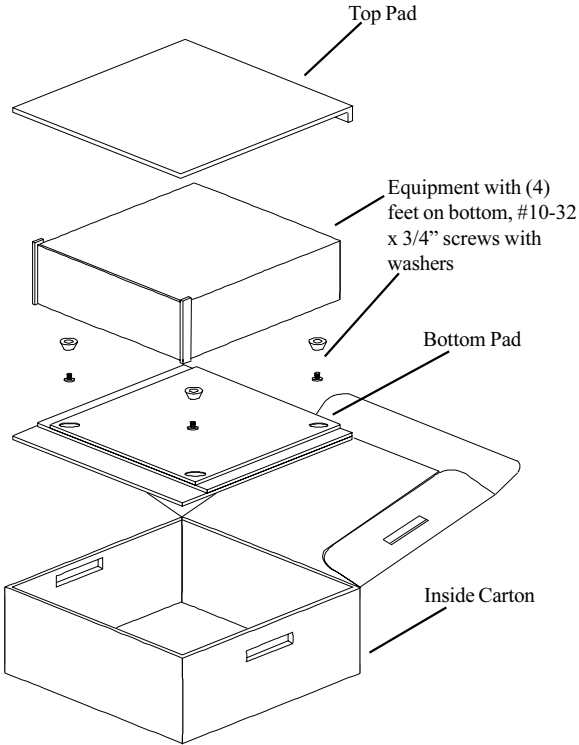

McIntosh[®]

McIntosh Laboratory, Inc.
2 Chambers Street
Binghamton, NY 13903