

McIntosh

McIntosh Laboratory, Inc. 2 Chambers Street, Binghamton, New York 13903-2699 Phone: 607-723-3512 www.mcintoshlabs.com



PS2K

POWERED SUBWOOFER

OWNER'S MANUAL





Thank You from all of us at McIntosh

You have invested in a precision instrument that will provide you with many years of enjoyment. Please take a few moments to familiarize yourself with the features and instructions to get the maximum performance from your equipment.

If you need further technical assistance, please contact your dealer who may be more familiar with your particular setup including other brands. You can also contact McIntosh with additional questions or in the unlikely event of needing service.

McIntosh Laboratory, Inc.

2 Chambers Street
Binghamton, New York 13903

Technical Assistance (607) 723-3512
Fax (607) 724-0549

Customer Service (607) 723-3515
Fax (607) 723-1917

Email support@mcintoshlabs.com
www.mcintoshlabs.com

Please Take A Moment

For future reference, you can write down your serial number and purchase information here. We can identify your purchase from this information if the occasion should arise:

Serial Number: _____

Purchase Date: _____

Dealer Name: _____

Table of Contents

Performance Features	3
General Information	4
Packing and Unpacking the PS2K..	4
Connector Information	4
Signal Flow Block Diagram	5
Installation	6
Front View	7
Rear Panel	8-9
How to Connect	10
Subwoofer/LFE Connection Diagram	10
Chain Connection Diagram	11
Two Channel Connection Diagram	12-13
Troubleshooting	14
Specifications	14
General Specifications.	14
Packing Instructions	15
Part List	15

Introduction

The McIntosh PS2K Powered Subwoofer is designed for Home Theater and Music Reproduction. The PS2K has four 13 inch LD/HP woofers powered by their own 500 watt amplifier. The woofers also contains built-in High and Low Pass Filters, and two Parametric Equalizer Filters for room correction.

The PS2K Powered Subwoofer complements the capabilities and the remarkably low distortion of McIntosh systems.

Each component in the PS2K has been carefully designed for durability, efficiency, and low distortion. The McIntosh PS2K Powered Subwoofer will reproduce music accurately, and function as an excellent Powered Subwoofer.

Safety First

Please read the safety instructions included in a separate document called **INSTRUCTIONS: Safety, Hearing, Protection, Disposal**

Safety Cover

The PS2K is factory equipped with a clear safety cover on the rear surface. Do not remove this cover for any reason, and never make any other electrical connection to the terminals inside.

- **Woofers with Patented LD/HP® Technology**
 The McIntosh Low Frequency Loudspeaker Elements feature the patented LD/HP Magnetic Circuit Design. This design, when compared to conventional Loudspeaker Drivers, reduces distortion significantly, and increases power handling.
 The die cast basket has an open-air area under the voice coil/spider assembly to prevent displacement noise. The carbon fiber cone performs as a near-perfect air piston, with a corrugated surround, and a six-layer high temperature voice coil.
 All together, these advances in woofer design construction and materials produce the very important first several octaves of music, with a high degree of accuracy and superb transient response. The performance of the PS2K rivals that of woofers twice its size.
- **Gold Plated Input Connectors**
 The PS2K Input Connectors are gold plated for superior corrosion resistance and high electrical conductivity.
- **Low Harmonic and Intermodulation Distortion**
 The PS2K Loudspeaker System is capable of reproducing the full dynamic range of a symphony orchestra with very low audible distortion of any kind.
- **Sealed Enclosure**
 The PS2K uses acoustic suspension design techniques. This type of loading was pioneered decades ago, using a linear air spring to keep distortion low, control suspension, and provide an extended low frequency output below resonance.
- **Large Woofer with Integral Heat Sink**
 Massive dual magnets with thick front and back plates provide a heat sink for the voice coil. The voice coil itself is wound on a 3" diameter aluminum bobbin to aid in the dissipation of heat. The ability to dissipate heat greatly improves the driver's capacity to perform at high power levels and not suffer from power compression.
- **Rigid Woofer Framework**
 A black powder coated, die cast aluminum basket is used as the framework for the driver. Such framework is necessary to keep the driver's moving components aligned during the long excursions a subwoofer can produce.
- **Rigid Woofer Cone**
 The PS2K uses custom designed unified carbon fiber cone, dust cap, and coil mounting technology. This provides exceptional cone rigidity to assure no cone breakup under the most demanding conditions. Additionally, the corrugated style cone suspension provides extended linear cone travel over most woofer designs.
- **High Power and Low Distortion**
 The PS2K's four 500 watt Amplifiers have very low Total Harmonic Distortion (THD). This 0.05% THD rating combined with the low distortion of the McIntosh LD/HP Driver provides exceptionally smooth and clean low frequency response.
- **Power Guard**
 The patented McIntosh Power Guard circuit prevents the PS2K Amplifier from being over driven into clipping, which causes harsh distorted sound that can also damage loudspeakers.
- **Signal Sensing Circuitry**
 In addition to the McIntosh Remote Power Control feature, the PS2K utilizes signal-sensing circuitry. This signal sensing circuitry is beneficial when the PS2K is to be located at a great distance from the pre-amp and running an additional Power Control Cable is not feasible.
- **Phase Control**
 The continuously variable phase control provides precise adjustment for the subwoofer phase.
- **Balanced and Unbalanced Inputs/Outputs**
 Balanced connections guard against induced noise and allow long cable runs without compromising sound quality.
- **Sentry Monitor and Thermal Protection**
 McIntosh Sentry Monitor power output stage protection circuits ensure the PS2K will have a long and trouble free operating life. Built-in Thermal Protection Circuits guard against overheating.
- **Parametric Filter**
 The Parametric Filter provides simple peak or dip filtering to the subwoofer output for room effect correction. These filters may be used to independently from any other room correction methods.
- **Signal Pass Through**
 Signal Pass through is used for easy chaining of one PS2K to another.

General Information

- The PS2K's Power Control Input will function within a 5 to 20 DC Voltage range. The Power Control Output will only send a signal if a source is connected to the Power Control Input.
- To avoid damage, do not connect the speaker level output terminals from any receiver, amplifier or integrated amplifier to the inputs of the PS2K Powered Subwoofer.
- The PS2K needs to be connected to a dedicated circuit with AC outlet. The type and size of the dedicated AC circuit with outlet needs to be in accordance with the local electrical wiring codes. Always contact your McIntosh dealer and certified electrician for additional information and assistance.

Note: 20 Amp, 120 volt AC circuit for use in the United States and Canada only.

Packing and Unpacking the PS2K

Warning: *The PS2K is very heavy (458 lbs). Please refer to Unpacking instructions located in a envelope attached to the shipping crate. Be sure to have the appropriate manpower available to handle safely.*

The PS2K is finished in a highly polished and durable paint, but it can be scratched. Ensure all sharp objects like rings, belt buckles, watches, etc are removed prior to handling. Please note the PS2K has no protective covers or grilles over the woofers. Do not grab the woofers.

Once removed and placed in the listening area, slowly remove the protective film, and remove the rubber ring on the metal base.

Packing the PS2K is the reverse of unpacking, so please be sure to save all instructions and materials.

Connector Information

XLR Connectors

Below is the pin configuration for the XLR balanced output connectors on the PS2K. Refer to the diagram for connection:

- PIN 1: Shield/Ground
- PIN 2: + Input/Output
- PIN 3: - Input/Output

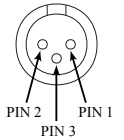

Power Control Connectors

The PS2K POWER CONTROL INputs and OUTputs on the rear panel send and receive power on/off signals when connected to other McIntosh components. A 3.5 mm stereo mini plug is used for the connections.

Meter illumination can also be controlled via the Power Control Input's source.

Note: A complete line of custom McIntosh power control cables are available, starting with the "CCIM" 1-meter cable.

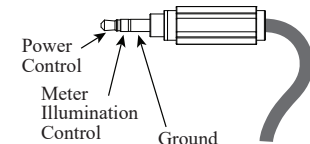

RCA Connectors

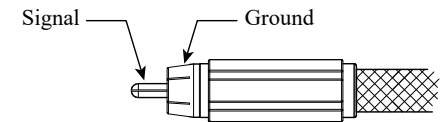

Signal Flow Block Diagram

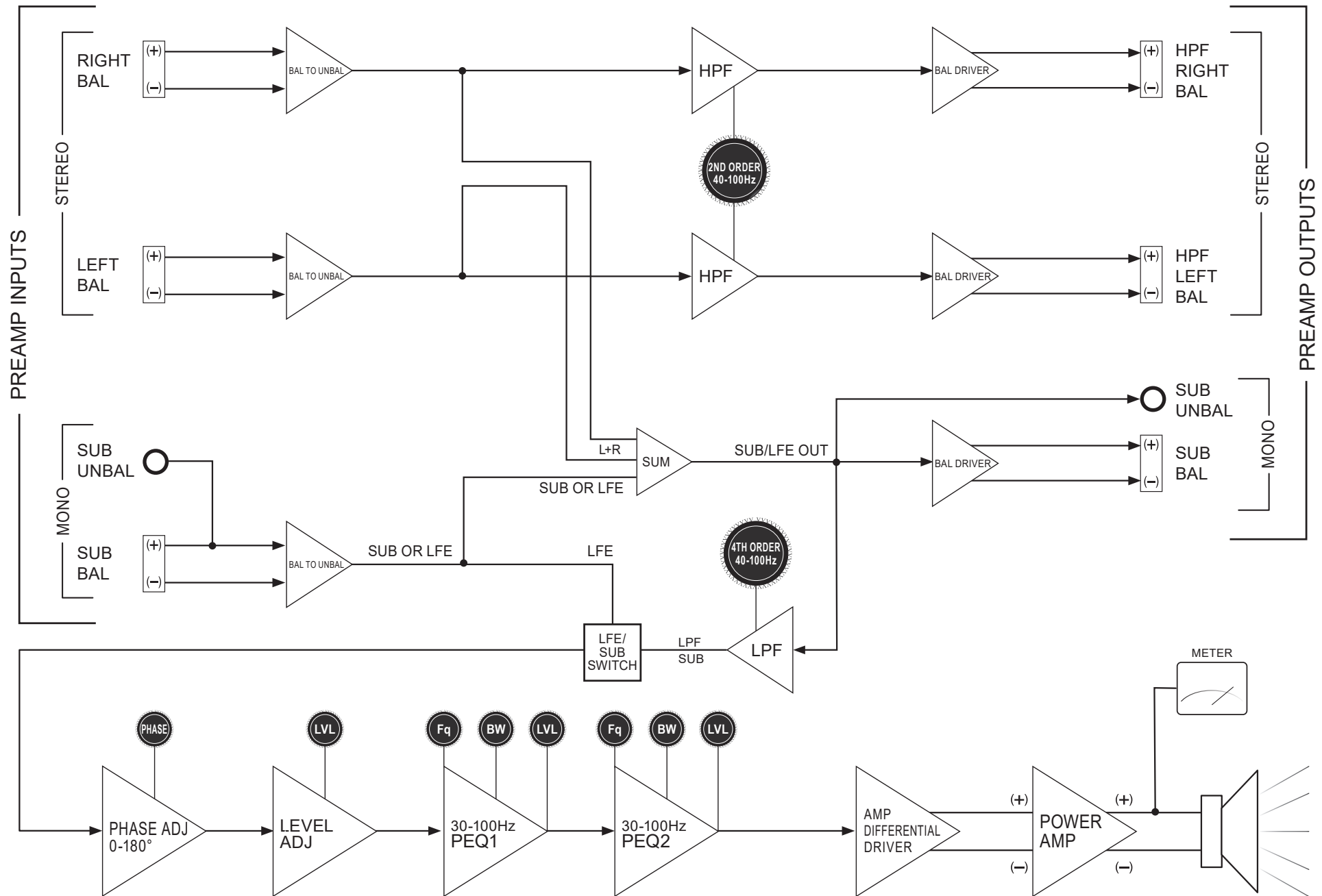

The following dimensions can assist in determining the best location for the PS2K Powered Subwoofer.

A Note on Placement:

To protect the anodized finish on the PS2K, it is important to limit exposure to certain types of lighting, and only use appropriate gentle cleaners. Direct sunlight, other forms of UV light, high intensity lighting, and chemical cleaners can result in discoloration of the anodized finish.

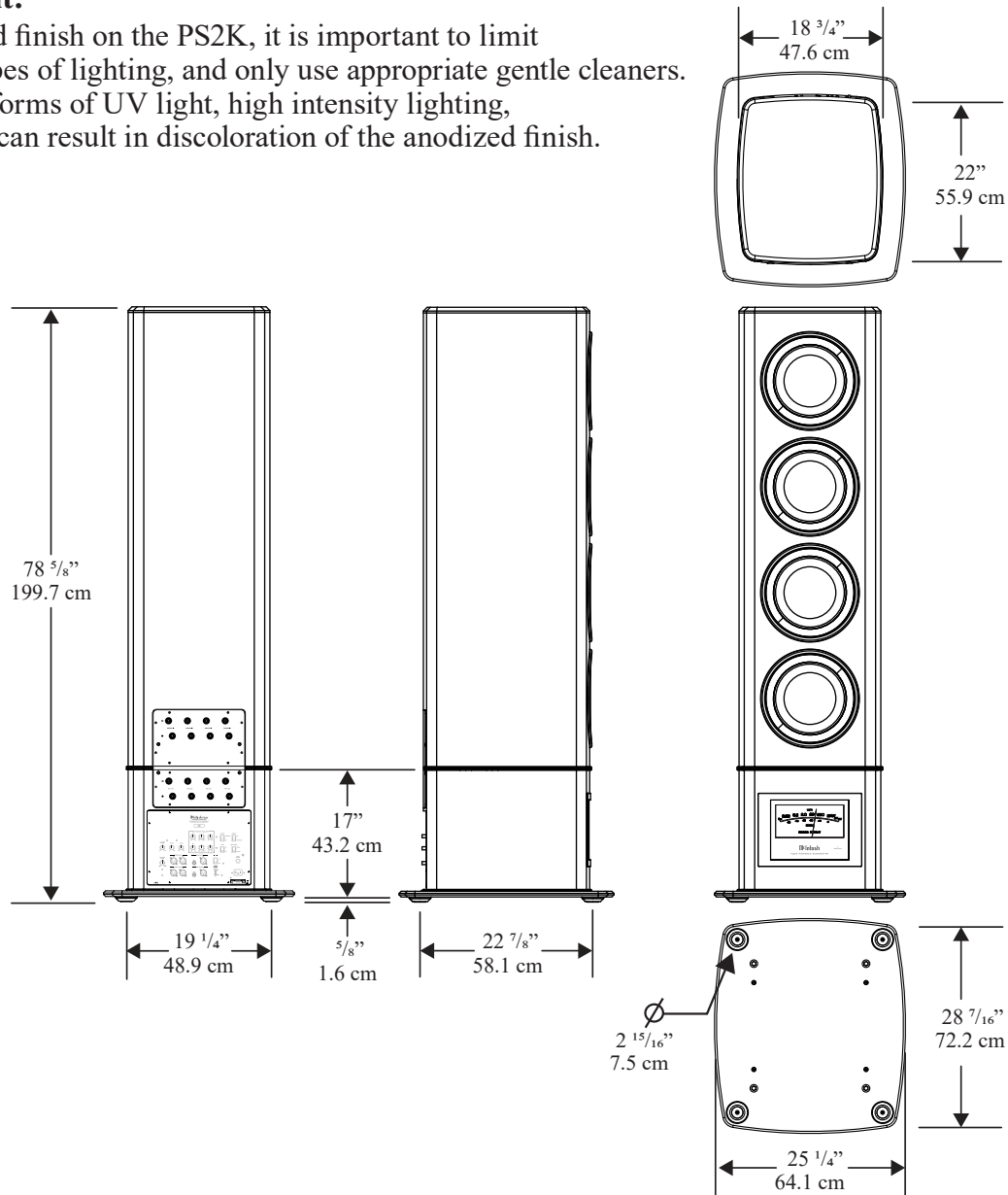

Locating the PS2K

The optimal method for selecting speaker locations includes the use of a real time spectrum analyzer (RTA) operated by an experienced system installer. For an uncompromising installation, take into consideration the floor, wall, and ceiling coverings. Keep in mind the type and placement of furniture, the architectural design of the room, and its construction materials. Frequencies 80 Hz and below reproduced by the PS2K Powered Subwoofer are non-directional, and will sound best located toward the front of the room and away from corners. It is not necessary to aim the front of the PS2K directly at the listener.

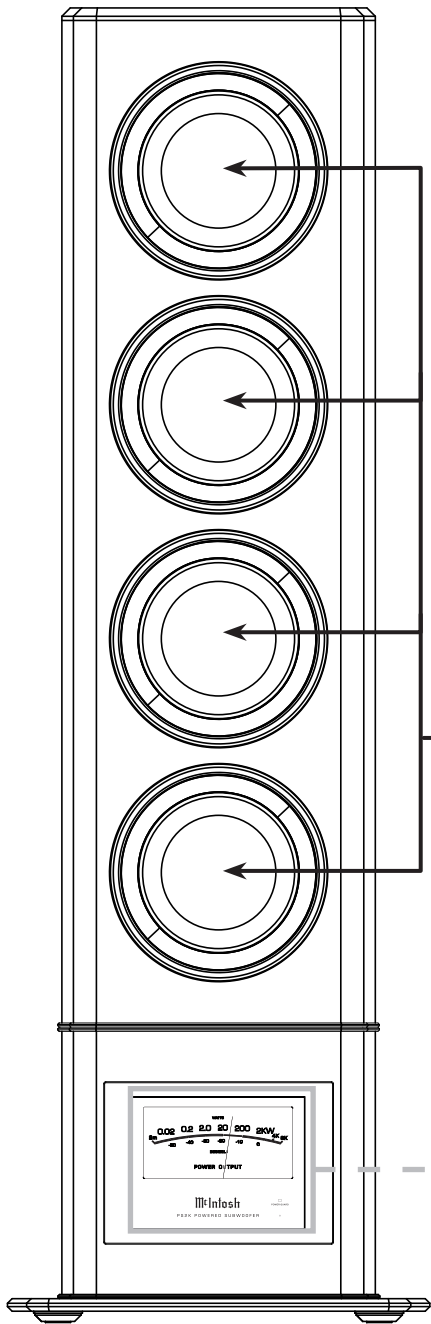

1. **Extra-long excursion carbon fiber cone woofers** outputs sound from the components connected to the PS2K.
2. **POWER OUTPUT** meter indicate the power being output by the PS2K.
3. **POWER GUARD LED** illuminates when the power guard circuit activates to control excessive distortion in audio.
4. **Standby LED** indicates that the PS2K is connected to power and ready to be turned on via the rear panel switch or rear panel power control.

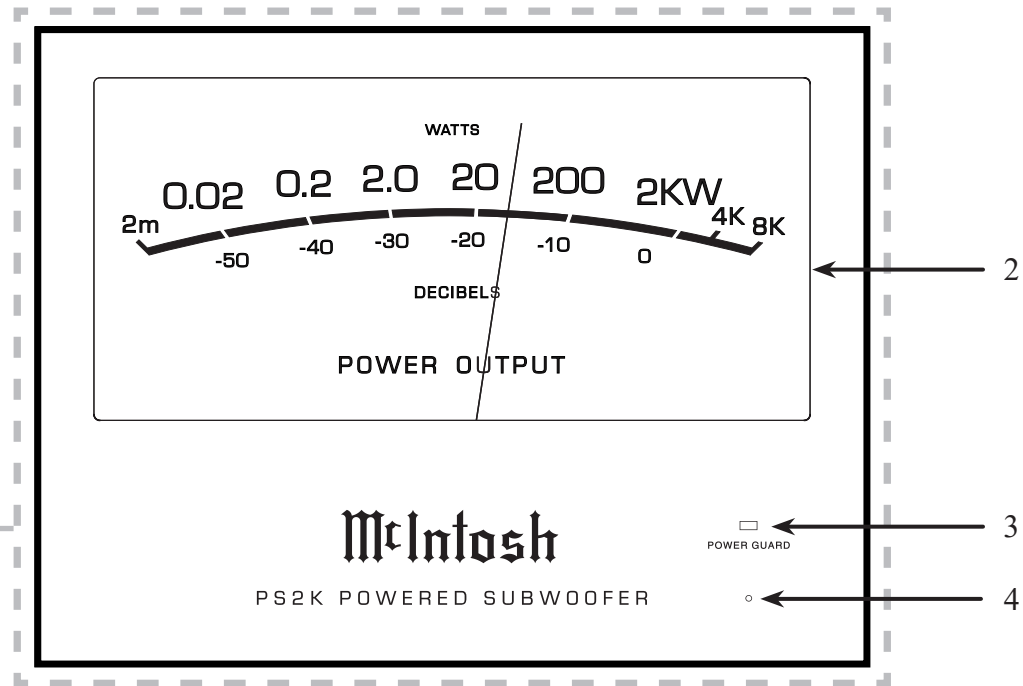

1. LOW PASS FILTER allows for an adjustable cut-off frequency between 40 Hz and 100 Hz to the subwoofer. This setting is typically set to match the HIGH PASS FILTER setting. The LOW PASS FILTER is always used if connected to Left and Right Inputs. To apply the LOW PASS FILTER, the TYPE switch must be set to SUB.

2. HIGH PASS FILTER allows for an adjustable cut-off frequency between 40 Hz and 100 Hz, from the normal left and right loudspeakers. This lowers distortion, prevents overloading the left and right loudspeakers, and provides optimal blending with the Subwoofer output. To use the HIGH PASS FILTER, connect the L and R output of a preamplifier, or integrated amplifier to the left and right inputs of the PS2K. Connect the L and R outputs of the PS2K to the power amplifier(s), and set the crossover frequency depending on the size and/or specifications of the loudspeakers. Suggested settings would be 40 Hz for very large loudspeakers, 60 Hz for medium size loudspeakers, or 80 Hz for smaller speakers. If setting the PS2K for Home Theater use, the AVR will typically have these settings internally. If this is the case, then no L and R connection, or setting changes are required on the PS2K.

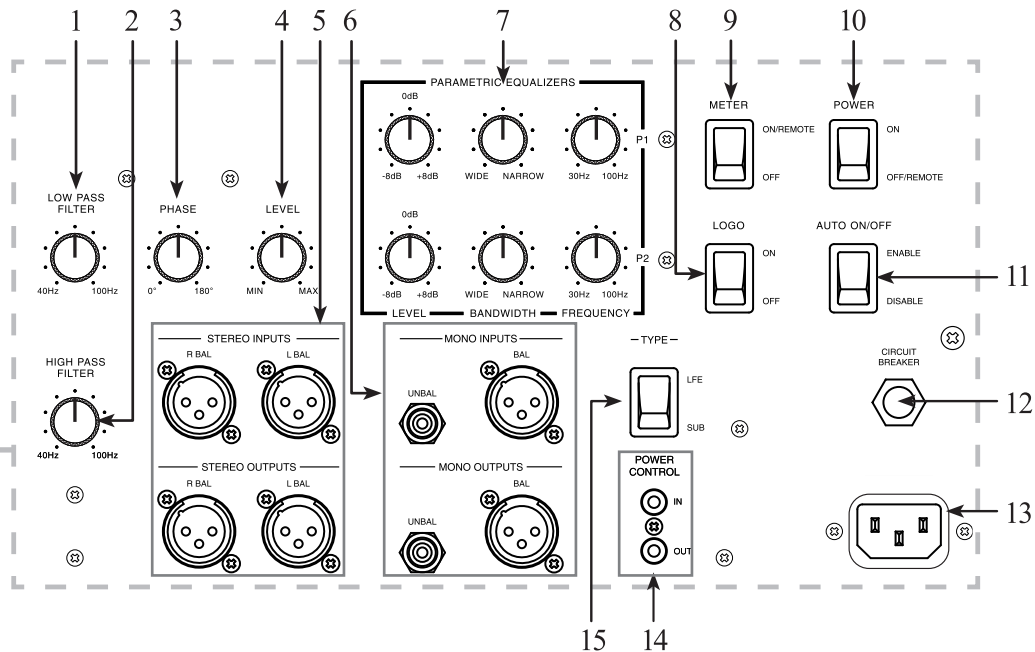
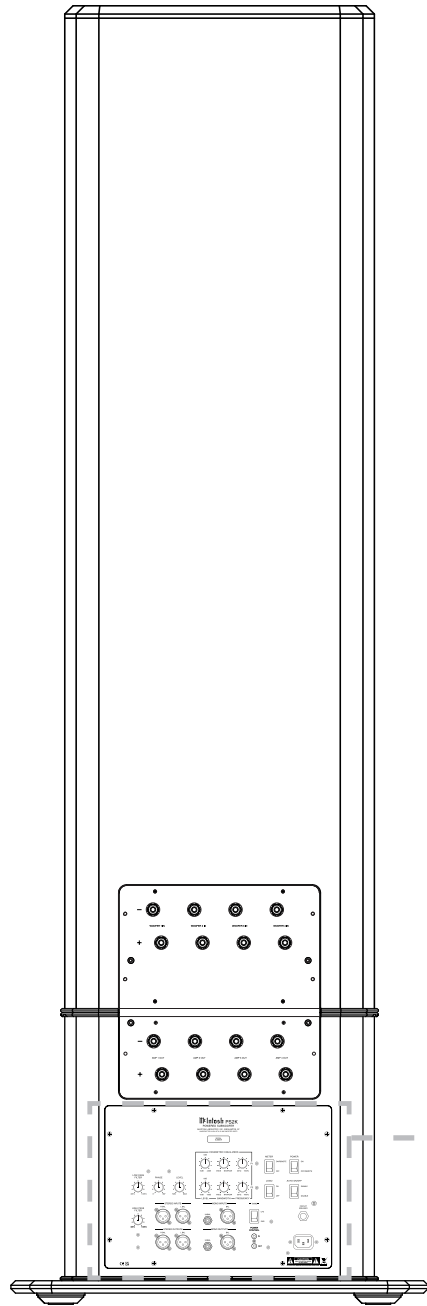

- 3. PHASE knob** sets the acoustic output phase to provide optimum blending into a system relative to its input. This knob is to help avoid phase cancellation (loss of bass information) between the PS2K, and any other low frequency producing speaker in the system. Carefully listening while turning the PHASE knob will help determine if this effect will be beneficial to the system.
- 4. LEVEL knob** sets the gain / balance of the subwoofer's output to match the rest of the system. Start with the LEVEL knob in the center position, and perform the system level-calibration on the a/v control center, or surround decoder for the subwoofer level. If the subwoofer level can not be set, adjust the PS2K's LEVEL knob to provide adequate range during calibration.
- 5. STEREO INPUTS** are used in a two-channel music system, or a system where a preamplifier or AVR is not applying LOW, or HIGH PASS FILTERS to any loudspeaker output channel. If applicable, connect the preamplifier, or AVR Left and Right outputs to the PS2K Left and Right Inputs.
STEREO OUTPUTS are used to connect to Left and Right amplifier inputs of an integrated amplifier, AVR, or Left and Right loudspeaker amplifier after the HIGH PASS FILTER is applied. Never connect the speaker level outputs of an AVR, or 2 channel integrated amplifier to the Stereo inputs of the PS2K.
- 6. MONO INPUTS** connect to the output of another PS2K, or other components in a system. If connected to the output of another PS2K or other subwoofer, then select SUB on the TYPE switch. If connected to the LFE output of a preamplifier, or AVR that has the ability to apply a custom filter setting, select LFE on the TYPE switch.
- MONO OUTPUTS** connect to the input of another PS2K, or other subwoofers in a system. When the TYPE switch is set to SUB, the output will be the sum of both the Stereo and Mono inputs, and the internal LP filter of the PS2K is applied. If connected to the subwoofer output of an integrated amplifier, select SUB on the TYPE switch.
- 7. PARAMETRIC EQUALIZERS** provide adjustments for room effect compensation. The filters are applied only to the subwoofer output. The available filter adjustments are Frequency, Bandwidth, and Level.
The best way to set the parametric filters is with the use of a spectrum analyzer, and a noise source. If unable to obtain a spectrum analyzer, play typical music and listen for lack of energy or output in the audio.
Troubleshooting the Parametric Filter
If a low output sound is heard in a particular frequency range, set the P1 filter level to +dB position. If higher output is noted, select a -dB position at that frequency.
Set bandwidth to center position, and play the signal material while adjusting the frequency control until a correction is heard. Adjust the frequency knob until it is centered on the effect. Next, adjust the level control until the sound is more uniform. Further adjustment of the bandwidth control localizes the correction to only the band where the action is desired.
The P2 filter may be adjusted in a similar manner if the sound output is lacking energy or character. Parametric filters can be bypassed by placing their LEVEL control to 0 dB.
- 8. LOGO switch** controls the McIntosh logo lighting.
- 9. METER switch** controls the PS2K's meter lighting. When ON, the PS2K will accept power control signals from other components to control the meter lighting.
- 10. POWER switch** controls power capabilities. When set to the OFF position, the PS2K can only be turned on by a remote power control signal. When set to the ON position, the PS2K will stay on depending on the position of the AUTO ON/OFF switch. Using an active Power Control signal will disable this circuitry.
- 11. AUTO ON/OFF switch** allows the PS2K to time out in the absence of audio after 30 minutes. If Audio is detected, the PS2K will trigger back ON. Using an active Power Control signal will disable this circuitry.
- 12. CIRCUIT BREAKER** should never activate under normal conditions. If the breaker does activate, the tip of the breaker will pop out. Reset the breaker by pushing in on the tip.
- 13. AC input** is used to connect the PS2K to an AC outlet.
- 14. POWER CONTROL IN and OUT** allows the PS2K to send, and receive signals to/from other components. Connect a power control cable to the input from a control center or preamplifier to automatically turn on the PS2K when the component is on.
Connect a power control cable to the output to send the signal to additional subwoofers, or other McIntosh components to automatically turn them on. For the output to function, a source must be connected to the POWER CONTROL input.
- 15. Input TYPE switch** allows for the control of LFE and SUB signals. If receiving audio with filters already applied to its signal, set switch to LFE. If receiving unfiltered audio, set type to SUB.

The McIntosh PS2K Powered Subwoofer may be turned On or Off by two different methods. The preferred method is to utilize the Power Control Signal from a McIntosh A/V Control Center or Audio Control Center. If the Power Control Signal is not available, the PS2K has built-in signal-sensing circuitry which will automatically turn-on the Powered Subwoofer.

1. Connect a power control cable from the McIntosh A/V Control Center or Audio Control Center Power Control Out Jack to the McIntosh PS2K POWER CONTROL IN Jack.
2. Connect a power control cable from the McIntosh PS2K POWER CONTROL OUT Jack to the McIntosh Power Amplifier Control In Jack.

Notes: • If two or more McIntosh PS2K Powered Subwoofers are being used in the same system, connect the POWER CONTROL OUT from the first PS2K to the next PS2K POWER CONTROL IN Jack and then onto the McIntosh Power Amplifier.

- The PS2K's Power Control Input will function with 5 to 20 Volts DC applied.
- The PS2K Power Control output requires connection of a switched Power Control input to function.

3. Connect a Balanced Audio Cable from the McIntosh A/V Control Center or Audio Control Center Subwoofer Out to the McIntosh PS2K MONO INPUT(S).

Notes: If two or more McIntosh PS2K Powered Subwoofers are being used in the same system, connect a second Audio Cable from the first PS2K MONO OUTPUT(S) to the next PS2K MONO INPUT(S).

4. Connect the PS2K power cord to an active AC outlet.

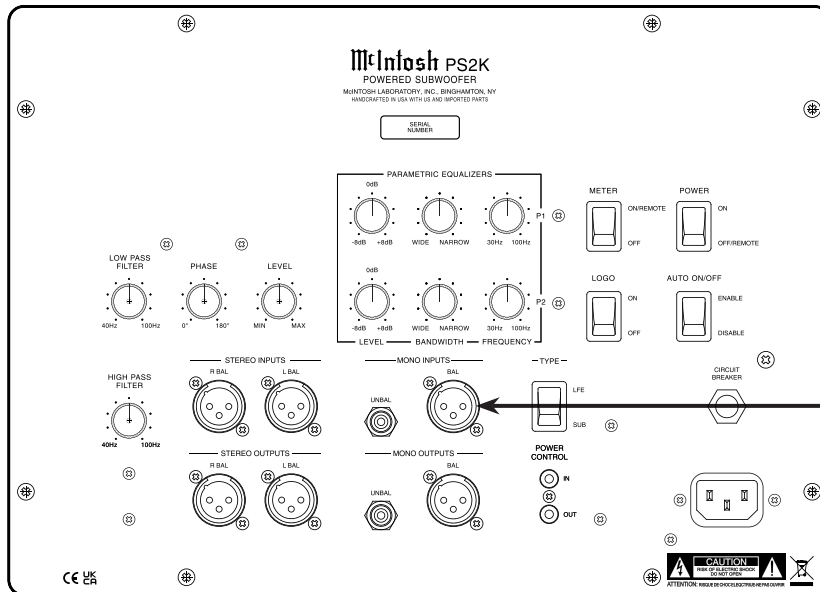

Subwoofer/LFE Output Connection Diagram

Home Theater Connection

Typical AVRs or AV processors will apply custom subwoofer filter settings. Connect an AVR, subwoofer, or LFE output to the mono subwoofer input of the PS2K. The TYPE Switch should be set to LFE.

Home Music System Connection

Connection to a pre-amplifier or music processor / integrated amplifier is made from the subwoofer output to the mono subwoofer input of the PS2K.

- If the pre-amplifier or music processor has an available adjustable crossover setting, use it and set the TYPE Switch to LFE. If the pre-amplifier or music processor does not have a adjustable setting, set the TYPE Switch to SUB.

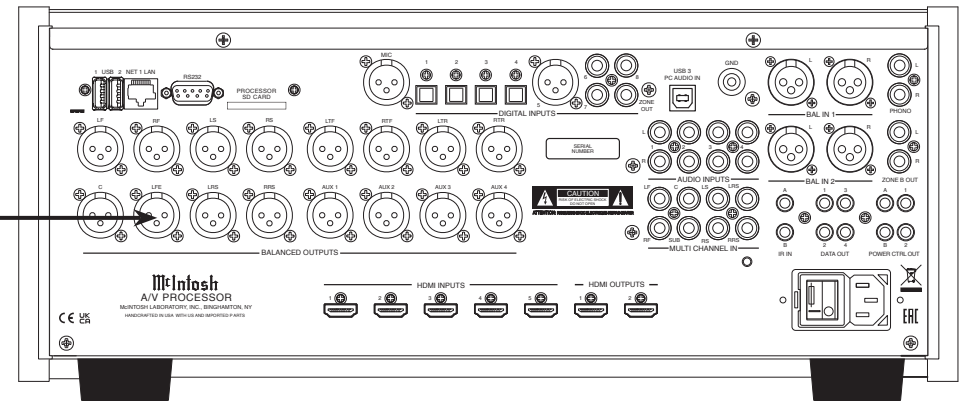

Chain Connection Diagram

To connect multiple PS2Ks to an A/V Processor in a single system use the following connections:

- The TYPE switch should be set to SUB, this allows for signal path to go through the LOW PASS FILTER.
- The LOW PASS FILTER should be set to the L and R loudspeaker's rated low frequency point. This is typically 40 Hz for large loudspeakers, 60 Hz for medium size loudspeakers, and 80 Hz - 100 Hz for small loudspeakers.
- The HIGH PASS FILTER should be set to match the LP filter setting.

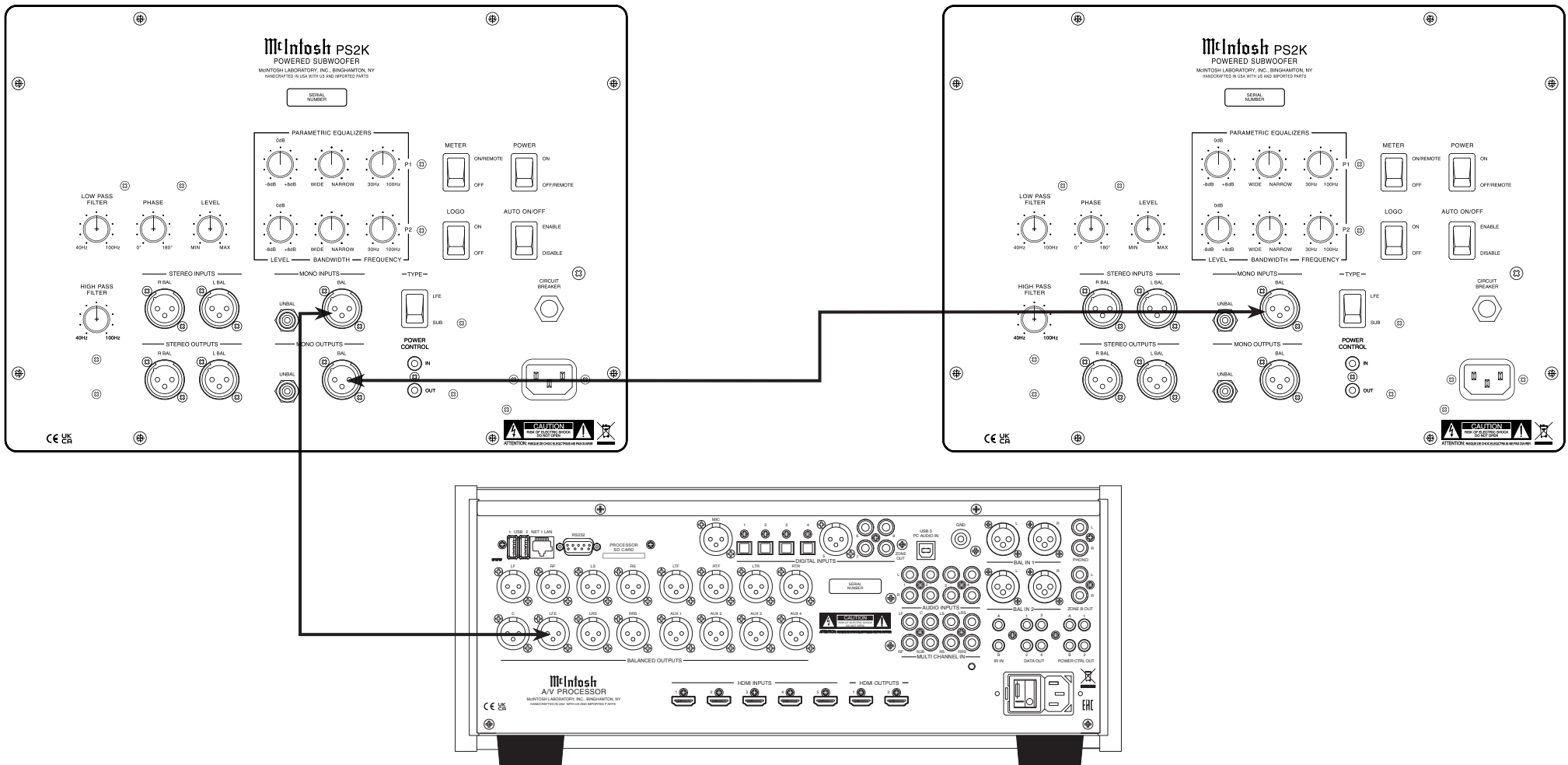

Two Channel Connection Diagram

Home Music System Connection

Connection to a Preamplifier or Music Processor / Integrated Amplifier without a dedicated subwoofer output is made from the Left and Right line level outputs to the Left and Right inputs of the PS2K. Using this method allows filtering of low frequencies from the Left and Right loudspeakers in a system, relieving them of the low frequency burden, reducing their distortion, and optimally blending the output of the subwoofer and loudspeakers.

- The LOW PASS FILTER should be set to the L and R loudspeaker's rated low frequency point. This is typically 40 Hz for large loudspeakers, 60 Hz for medium size loudspeakers, and 80 - 100 Hz for small loudspeakers.
- The HIGH PASS FILTER should be set to match the LP filter setting used above.

Note: More than one PS2K may be chained in a music system setup. In this case, follow the chain from the first PS2K to the second, and set the TYPE to SUB. Set the LP filter to match the lead PS2K, and adjust parametric filters as necessary for smooth performance.

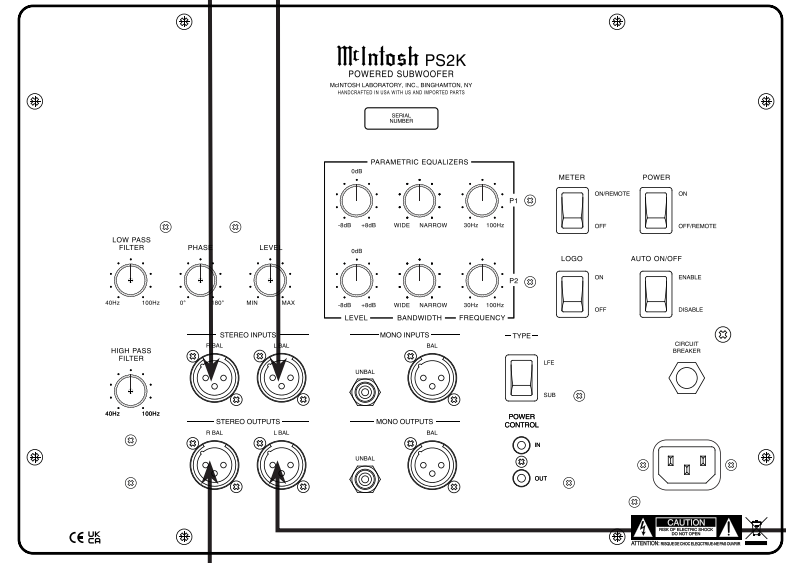
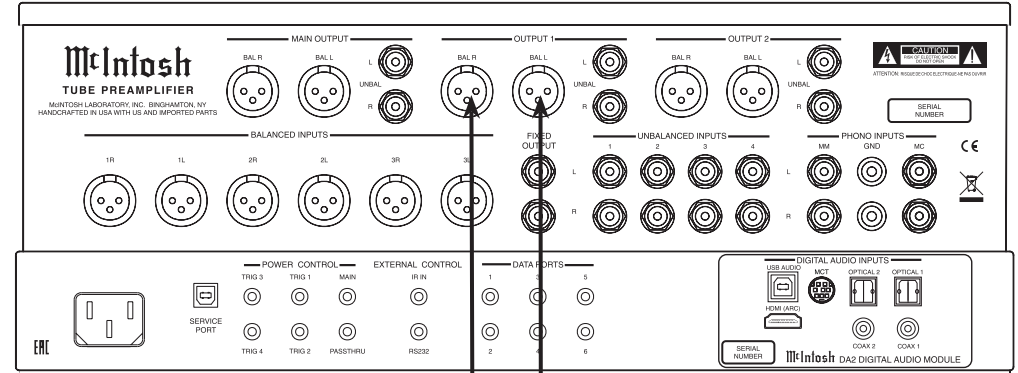

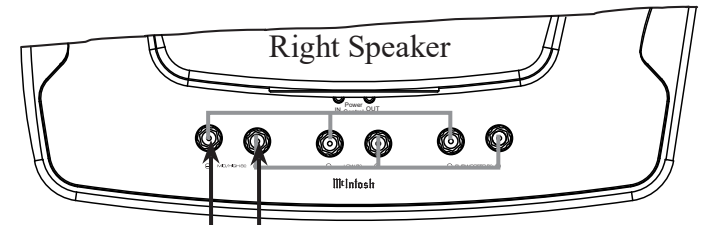
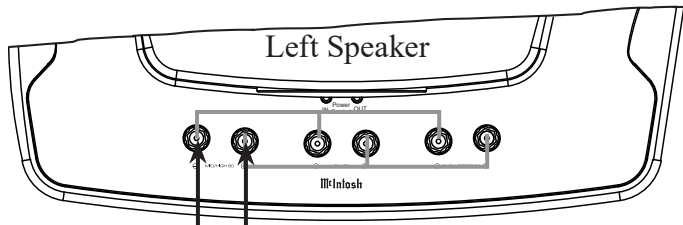

Left Channel Amplifier

Right Channel Amplifier

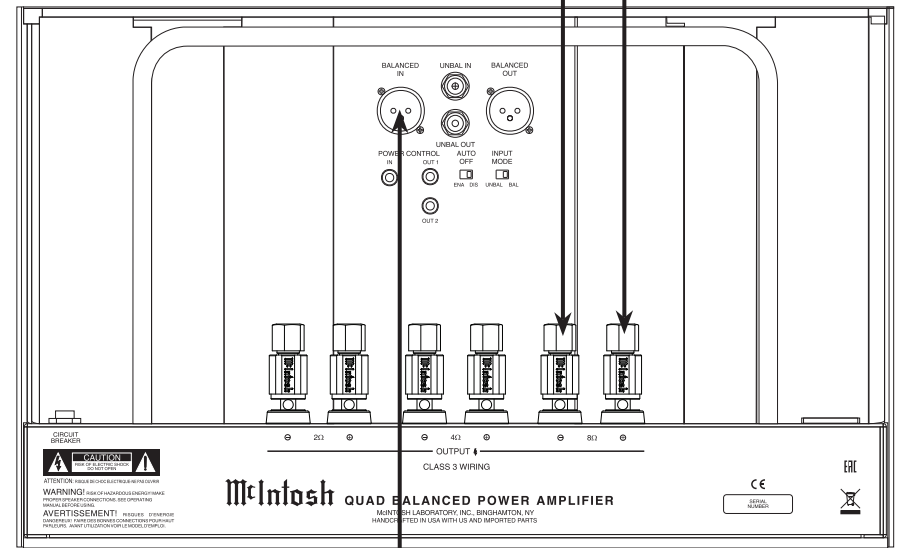
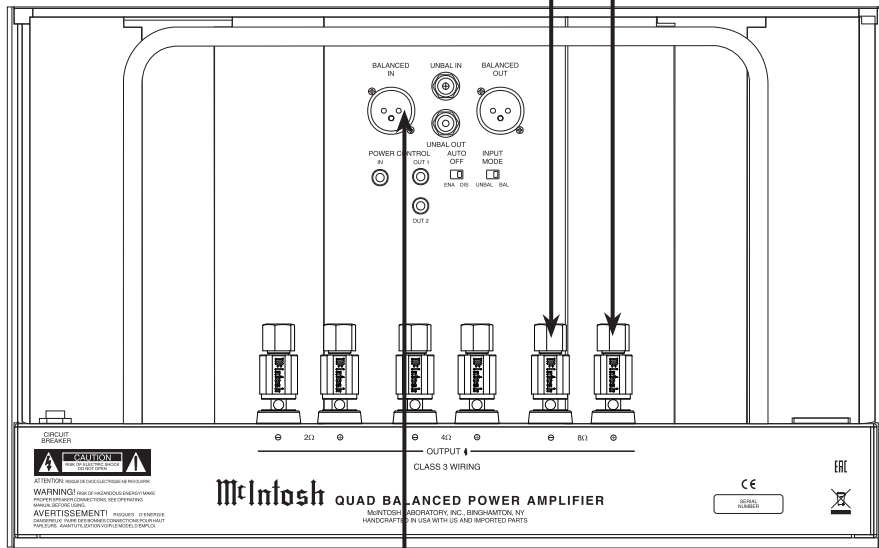

Before troubleshooting, attempt a system reset via the ON switch, or AC cycle. If a system reset doesn't change anything, utilize the methods below to fix the related issue.

Uneven Bass Output

- Use filter settings on the subwoofer to smooth out the sound output.
- Move the subwoofer to a new location in the room and test again.
- Place the subwoofer in the desired listening location, and listen at different locations in the room to determine the smoothest sound.

No Output

- Check the audio signal wires to correct source and subwoofer inputs.
- Check the input selection/LFE switch.
- Check source device volume.
- Adjust the PS2K level control.

If the problem persists, have an electrician test for power mains voltage conditions. McIntosh has set a protection threshold limit of 130 VAC 50/60 Hz and 260 VAC 50 Hz.

Specifications

System Driver Complement

Four 13 inch extra long excursion Carbon Fiber Woofers (incorporating LD/HP)

Impedance

8 ohms Nominal

FTC Power Output Rating

2,000 watts

Power Output

500 watts per woofer 20 Hz - 200 Hz

Filter Frequencies

High Pass: 40 Hz - 100 Hz

Low Pass: 40 Hz - 100 Hz

Phase: Continuously Variable

Parametric: Two band 30 Hz - 100 Hz, variable bandwidth and level +/- 8 dB

Input sensitivity (Rated Output)

550 mV Unbalanced

1.1 V Balanced

Total Harmonic Distortion + Noise

Amplifier: 0.05%

Preamplifier (Rear Panel Outputs): 0.005%

Voltage Gain

Amplifier: 20 dB

Preamplifier: 16 dB

Signal to Noise ratio (A-weighted)

Amp: 115 dB

Preamp: 100 dB

Input Impedance

20,000 Ohms Balanced

10,000 Ohms Unbalanced

Maximum Input Signal

4.5 V Unbalanced

9 V Balanced

Power Control In

5-20 VDC Trigger

Power Requirements

Field AC Voltage conversion of the PS2K is not possible. The PS2K is factory configured for one of the following AC Voltages:

100 Volts, 50/60 Hz at 6.0 amps

110 Volts, 50/60 Hz at 6.0 amps

120 Volts, 50/60 Hz at 6.0 amps

220 Volts, 50/60 Hz at 3.3 amps

230 Volts, 50/60 Hz at 3.3 amps

240 Volts, 50/60 Hz at 3.3 amps

Standby: approximately 0.25 watts

Note: Refer to the rear panel of the PS2K for the correct voltage.

General Specifications

Note: The PS2K has been tested and certified for indoor use only.

Enclosure Finish

Highly polished Piano Grade Black

Metal Finish

Anodized Aluminum Base, High Durability Powder Coated Plate Surfaces

Overall Dimensions

Width: 19 ¼ inches / 48.9 cm

Height: 78 ⅝ inches / 199.7 cm

Depth: 22 ⅞ inches / 58.1 cm

Base: 25 ¼ inches / 64.1 cm by 28 ⅞ inches / 72.2 cm

Weight

Net: 458 pounds / 207.7 kg

In shipping carton: 932 pounds / 422.7 kg

Shipping Carton Dimensions

Width: 36 inches / 91.4 cm

Depth: 54 inches / 137.2 cm

Height: 89 inches / 226.1 cm

Packing Instructions

In the event it is necessary to repack the equipment for shipment, the equipment must be packed exactly as shown in the unpack instructions. Use the original shipping carton and interior parts only if they are all in good serviceable condition.

If a shipping carton or any of the interior part(s) are needed, please call or write Customer Service Department of McIntosh Laboratory. Refer to page 2. Please see the Part List for the correct part numbers.

Part List

Qty	Part Number	Description
1	034735	Packing List Envelope
1	034720	Protective Bag
1	752871	Manual Pack
1	241286	Unpack Instructions

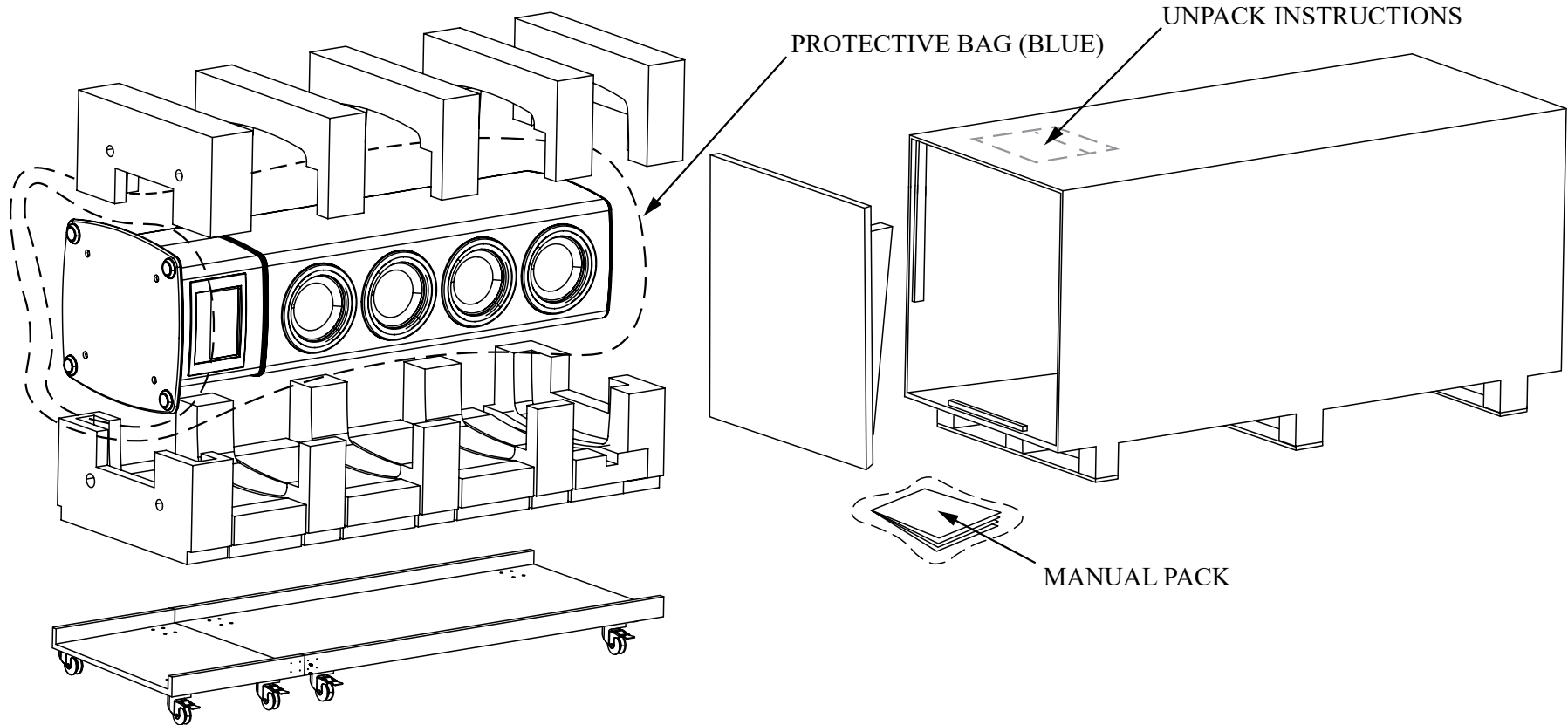

McIntosh®

McIntosh Laboratory, Inc.
2 Chambers Street
Binghamton, NY 13903
www.mcintoshlabs.com

The continuous improvement of its products is the policy
of McIntosh Laboratory Incorporated
who reserve the right to improve design without notice.

Trademarks of McIntosh Laboratory, Inc.:

The following are Registered Trademarks of McIntosh Laboratory, Inc in multiple jurisdictions around the world: the written McIntosh logo; the McIntosh Globe logo; the Mc logo; Power Guard; Power Guard Screen Grid Sensor; Power Guard SGS; LD/HP; Dynamic Power Manager; the 4DPM8 logo; HXD; the HXD logo; Behind The Sound; Legendary Performance.

The following are Trademarks of McIntosh Laboratory, Inc. in multiple jurisdictions around the world: Autoformer; Sentry Monitor; Solid Cinch; McIntosh Monogrammed Heatsinks; Hybrid Drive; DualView; TripleView; Made of Sound.

The foregoing trademarks, registered and otherwise, are not to be used, reproduced, or registered in any way without the express written permission of McIntosh Laboratory, Inc.